



**Roots**

## 409 RAM

Part Number – 82149020



- Heavy-duty unit with integral-shaft ductile iron impellers with an involute profile
- Rigid one-piece casing and headplates are grey iron
- Drive end cover and end cover are aluminum
- Carburized and ground alloy steel spur timing gears
- Cylindrical roller bearings
- Piston rings reduce air leakage
- Lip type oil seals prevent lubrication from entering the air chamber.
- Hydrodynamic seal on the drive shaft prevents oil leaks
- Splash oil lubricated gears on drive and gear ends
- Detachable steel mounting feet
- Horizontal and vertical configurations available

### Also Available in:

- RAM-J (Whispair)
- RAM-GJ (Gas Whispair)
- RAM-JT (Truck Mount Whispair)
- RAM-VJ (Water Sealed Exhauster Whispair)

### Equivalent to:

*Tuthill M-D Equalizer RM 4609*



816-741-0282



### Quick Specs

Flow Range	to 900 CFM
Max ΔPressure	18 PSI
Max ΔVacuum	16" Hg
Maximum RPM	4000
Minimum RPM	1750
Max ΔT	240°F
Connection Size	4" FPT
Shaft Dia.	1.5"
Min Sheave Dia.	7.1"
Drive End Lubrication	Oil
Gear End Lubrication	Oil
Oil Sump Horiz Config	~55 oz
Oil Sump Vert Config	~27 oz
Bare Unit Weight	300 lbs
Container	Wood Skid
Skid Size (L x W x H)	42" x 29" x 36"
Shipping Weight on Skid	~340 lbs
Recommended to Ship Via	Truck



816-741-0282

**RAM™, RAM™-J Series Parts List -  
4" and 6" Gear Diameter  
(Refer to drawing #81881023)**

Item #	Part Name	Qty.
1	Headplate	2
3	Gearbox	1
4	Timing Gears	2
5	End Cover	1
7	Gasket – Gearbox/Cover	2
10	Shims	Lot
11	Cylinder	1
12	Impeller & Shaft Drive	1
13	Impeller & Shaft Driven	1
14	Bearing Roller	4
16	Pin, Dowel (Pull Out)	4
17	Pin, Dowel	2
19	Key Square	1
21	Breather	2
22	Plug, Pipe	12
23	Screw, Cap Hex Hd.	*
27	Seal, lip headplate	4
28	Piston, Ring-Seal	4
29	Washer, Wavy Spring	2
31	Gear Nut	2
32	Scr, Cap Hex Hd.	16
33	Seal, Lip Drive	1
34	Brg. Clamp Plate - D. E.	2
35	Lock Washer - Spring	16
37	Sight Plug - Oil Level	2
38	Sleeve, Shaft	4
40	Slinger - D.E. (Top Drive)	1
46	Slinger - G.E.	1
49	Oil Leader L/S	1
50	Oil, Leader-R/S	1
54	Brg Clamp Plate - G. E.	2
60	Screw, Cap Butt. HD.	1
64	Pin, Spring	1
66	Screw, Cap Hex HD.	*
66.1	WHISPAIR™, Spring Lock 3/8M	*
70	Shims D.E. Brg.	1
75	Screw, Cap - Hex HD.	*
76	Blower Foot - RH	2
77	Blower Foot - LH	2
85	Elb, Pipe-Black	2
85.1	Plug, Pipe	2
87	Scr, Cap BH	2
88	Anti Rotation Ball	4
90	BSHG-RDCG	2
91	Washer, Plain Flat	2
92	Washer, Plain Flat	2
93	Washer	2
94	Oil Leader	2
95	Cap Screw	4

\*Quantity varies by blower.

**Repair Kits**

Repair kits are bundled with the parts you need to complete a standard repair. It is more cost effective to buy a repair kit than to purchase individual parts. However, if you need parts not listed in the kit, it is recommended that you call Pathfinder Systems for parts pricing.

**Top, Left, or Right Drive Shaft (Bottom Shaft order P/N 524574RK)  
P/N 524573RK Kit for 400 AIR RAM/RAM-J/RCS/RCS-J/DVJ/DPJ**

Item	Qty	Kit Description	P/N
		ASSY Slinger 400/600	TK10002
7	2	Gasket 400 RCS Gearbox/Cover	52381021
7	2	Gasket 400 RAM Gearbox/Cover	78365021
10	1	Shim Set 400 RAM/Roots-Flo	52378020
14	4	Bearing, Roller	T30054020
55	2	Plug, Vent 3/8"	13005003
21	2	Breather, Mini MB Style 1	T20013004
27	4	Seal, Lip(Viton),Main	10460030
28	4	Piston, Ring Seal	12283001
29	2	Washer, Spring, Wavy	10135018
31	2	Nut, Hex ESNA 1-1/4"-12	10319019
33	1	Seal, Lip, Drive	10460034
37	2	Sight, Plug Oil Level,1/2"	12066003
38	4	Sleeve, Piston Ring	52418020
40	1	DRIVE END SLINGER	54710020
46	1	GEAR END OIL SLINGER	T20029001
60/87	3	CAP SCREW 1/2-13x1	12800001
70	1	Shim (0.035) 400 RAM	10619141
88	4	Anti Rotation Ball	T20001001
91	2	BUSH ING STL	T20031001
93	1	GEAR END WASHER	90185020



816-741-0282

**Table 2 - Recommended Oil Grades**

Ambient* Temperature °F (°C)	ISO Viscosity No.
Above 90° (32°)	320
32° to 90° (0° to 32°)	220
0° to 32° (-18° to 0°)	150
Below 0° (-18°)	100

\*Ambient temperature is defined as the temperature of the space in which the blower and drive are located.

Use a good grade of **industrial type** non-detergent, rust inhibiting, anti-foaming oil and of correct viscosity per Table 2. Roots synthetic oil (Roots P/N 813-106-) is **specified and recommended**. Roots does not recommend automotive type lubricants, as they are not formulated with the properties mentioned above.

**Due to sludge build-up and seal leakage problems, Roots recommendation is DO NOT USE Mobil SHC synthetic oils in ROOTS blowers.**

RAM™, RAM™-J Approximate Oil Sump Capacities				
Orientation	Gearbox		Drive End	
	Fl. Oz.	Liters	Fl. Oz.	Liters
400 (Horizontal)	36	1.06	19	0.56
400 (Vertical)	18	0.52	9	0.27
600 (Horizontal)	95	2.81	50	1.48
600 (Vertical)	55	1.63	28	0.83

**ROOTS® Synthetic Oil: ISO-VG-320 Grade**

	Part Number
--	-------------

Quart	13106004
Gallon	13106005
Case (12 qts)	13106007

**ROOTS® Synthetic Oil: ISO-VG-220 Grade**

	Part Number
--	-------------

Quart	13106001
Gallon	13106002
Case (12 qts)	13106008

**ROOTS® Synthetic Oil: ISO-VG-150 Grade**

	Part Number
--	-------------

Quart	13106020
Gallon	13106021
Case (12 qts)	13106023
5 Gallon Pail	13106022
55 Gallon Drum	13106025

**ROOTS® Synthetic Oil: ISO-VG-100 Grade**

	Part Number
--	-------------

Quart	13106011
Gallon	13106012
Case (12 qts)	13106014
5 Gallon Pail	13106013
55 Gallon Drum	13106016

NOTES:

1. DRIVE END COVER TO BE PINNED TO HEADPLATE AFTER ALIGNING SEAL BORE WITH SHAFT WITHIN .001
2. USE TEFLON SEALANT ON ALL PIPE THREADS & CYLINDER TO HEADPLATE FLANGE FOR WHISPAIR GAS PUMP UNITS ONLY.
3. ITEMS 34 & 54 MUST BE INSTALLED WITH OIL GROOVE AT TOP.
4. TORQUE TO 400 FT.LBS. -400  
TORQUE TO 630 FT.LBS. -600
5. TORQUE TO 75 FT.LBS. -400  
TORQUE TO 140 FT.LBS. -600  
APPLY LOCKTITE TO SCREW THREADS & BOTH FACES OF WASHER & SLINGER.
6. TORQUE TO 35 FT.LBS. (HEADPLATE)
7. TORQUE TO 10 FT.LBS. (GEARBOX/END COVER)
8. LOCKTIGHT AND TORQUE TO FT.LBS. -75
9. TWO 1/2 X 3/4 BUSHINGS FOR BREATHERS ON 600 RAM SERIES ONLY

**BOTTOM DRIVE OPTION**  
ALSO SHOWN AS GAS SERVICE

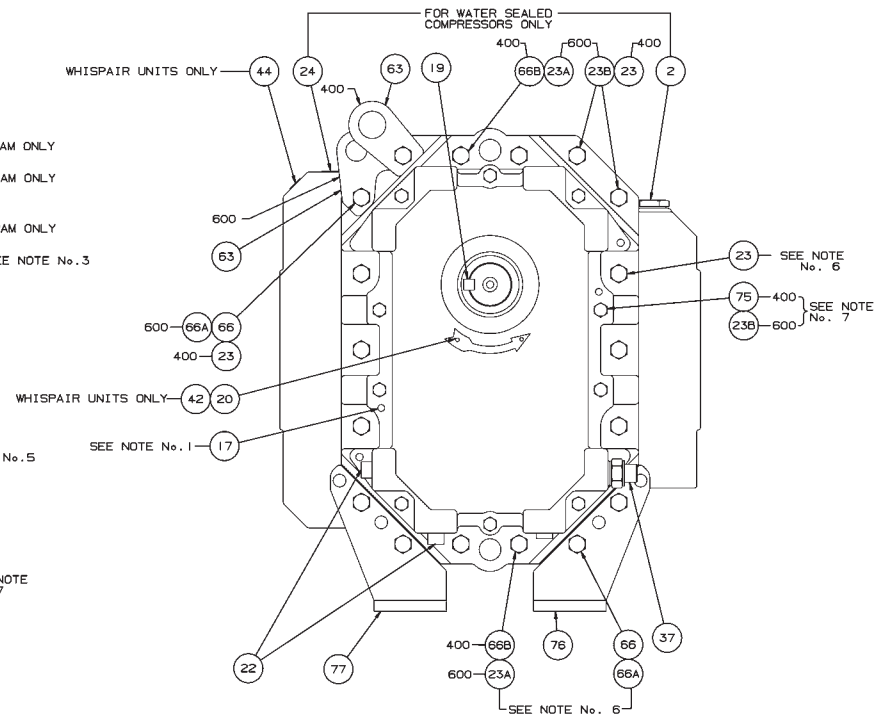
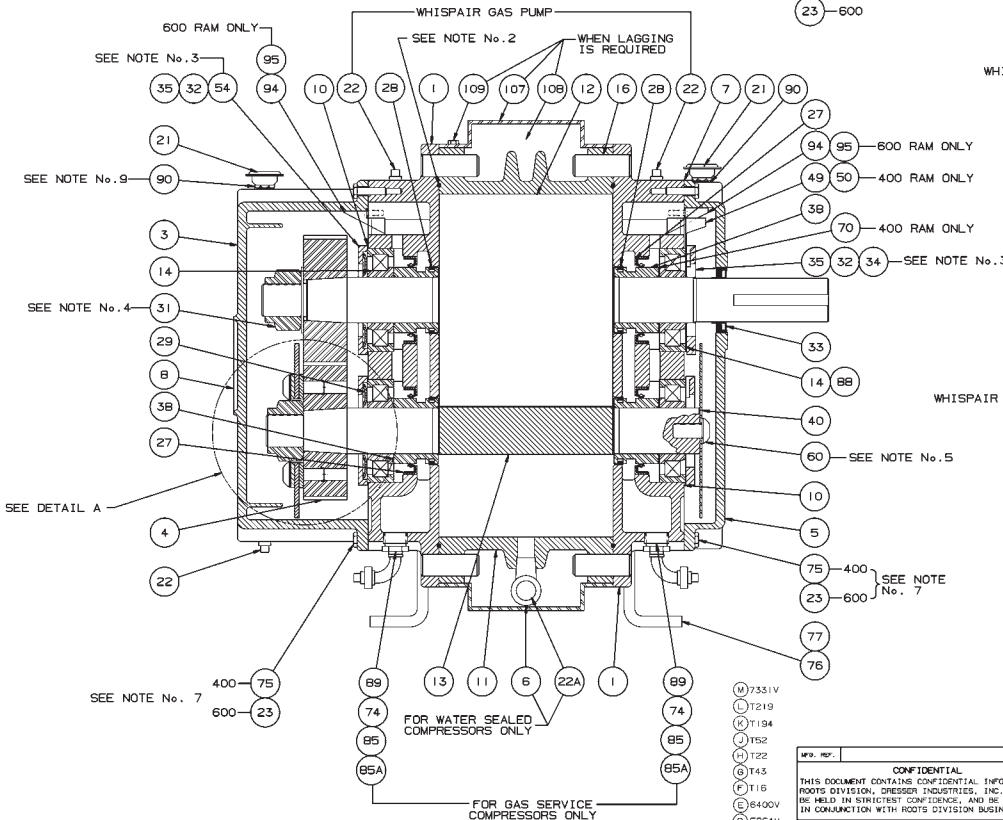
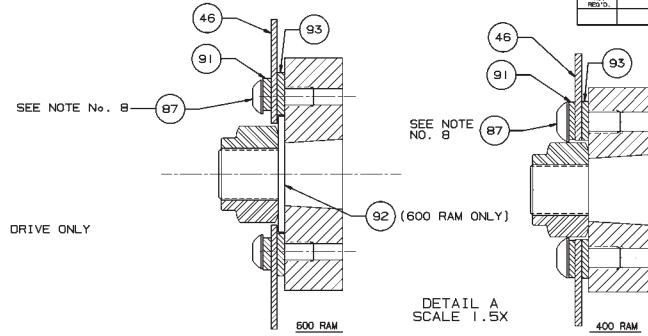
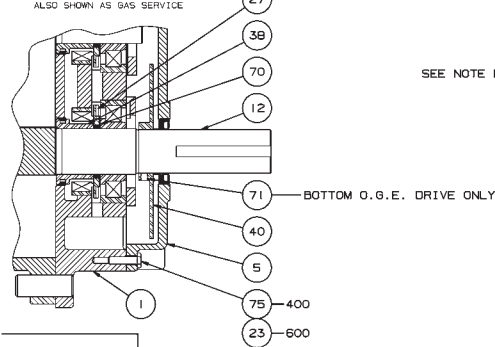

- (M) 7331V
- (L) T219
- (K) T194
- (J) T52
- (H) T22
- (G) T43
- (F) T16
- (E) 6400V
- (D) 5964V
- (C) 5757V
- (B) 5560V
- (A) 5048V

REV.	DATE	BY	CHKD.	APP.	DESCRIPTION
S	7/18/67	DAB	B203V		BOTT. DRIVE OPTION SLINGER REVERSED
R	1-26-68	AMP	7654V		REVISED GEAR END SLINGERS
G	9-1-68	AMP	7591V	RCA	ADDED NOTE TO ITEM 50 & 70
B	1-15-69	AMP	7430V	RCA	MOVED LIFTING LUG
D	3-6/69	RGR	7412V	RCA	ADDED 66B
N	2/2/69	YC	7331V	RCA	ADDED LAGSINS

RAM/RAM-J/RAM-GJ/RAM-VJ  
400/600 RAM

SECTIONAL ASSEMBLY

81881023

REV S

Assembly of RAM Series - Air & Gas Blowers

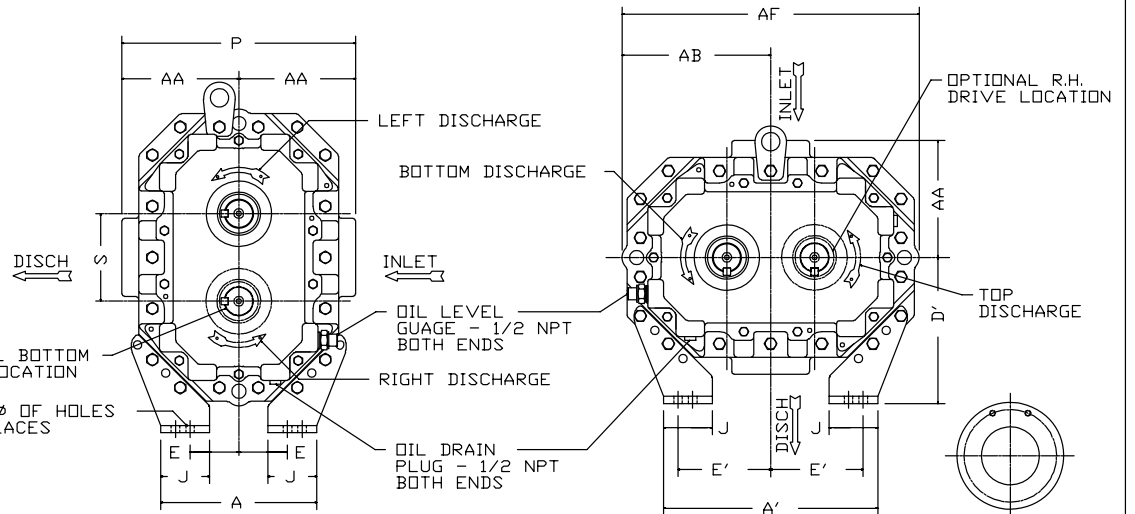
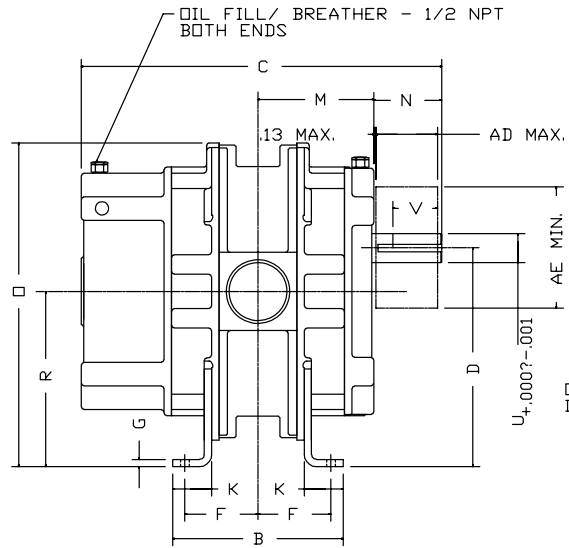

W - INLET  
 W' - DISCHARGE  
 AD - MAXIMUM SHEAVE WIDTH  
 (SEE OVERHUNG LOAD LIMIT K-24102)  
 AE - MINIMUM SHEAVE DIAMETER  
 (SEE OVERHUNG LOAD LIMIT K-24102)  
 ALL DIMENSIONS IN INCHES

INLET & DISCHARGE FLANGES TO MATE FLUSH & SQUARE WITH FLAT FACE FLANGE ONLY. USE FULL FACE GASKETS.  
 V-BELT DRIVEN UNITS: MOTOR TO BE LOCATED ON INLET SIDE OF BLOWER.

A 5048V B 5048V C 5560V D 5767V  
 E 5986V F 6006V

FLG	5"	6"	8"	10"
OPENING	5"	6"	8"	10"
BOLT CIRCLE	8.50	9.50	11.75	14.25
FLANGE O.D.	10.00	11.00	13.50	16.00
No TAPPED HOLES	8	8	8	12
SIZE HOLES	3/4-10	3/4-10	3/4-10	7/8-9
TAP DEPTH	1.13	1.13	1.13	1.13

FRAME SIZE	A	A'	B	C	D	D'	E	E'	F	G	H	J	K	M	N	O	P	R	S	U	V	KEYWAY	W	W'	AA	AB	AD	AE	AF	APPROX WEIGHT
404	8.00	11.00	8.75	18.50	11.25	7.50	2.50	4.75	3.75	.38	.44	2.50	2.00	5.95	3.48	16.63	12.00	9.00	4.50	1.50	2.75	.375X.188	3"NPT	3"NPT	6.00	7.63	3.06	7.10	15.25	230
406	"	"	10.75	20.50	"	"	"	"	4.75	"	"	"	"	6.95	"	"	"	"	"	"	"	"	4"NPT	4"NPT	"	"	"	"	"	260
409	"	"	13.75	23.50	"	"	"	"	6.25	"	"	"	"	8.45	"	"	11.00	"	"	"	"	"	"	"	5.50	"	"	"	"	300
412	"	"	16.75	26.50	"	"	"	"	7.75	"	"	"	"	9.95	"	"	"	"	"	"	"	"	6"FLG	6"FLG	"	"	"	"	"	360
418	"	"	22.75	32.50	"	"	"	"	10.75	"	"	"	"	12.95	"	"	"	"	"	"	"	"	8"FLG	8"FLG	"	"	"	"	"	440
616	9.00	15.00	20.75	32.19	15.00	9.00	3.50	6.50	9.75	.38	.56	2.50	2.00	12.41	4.30	22.00	14.50	12.00	6.00	2.00	3.63	.500x.250	8"FLG	8"FLG	7.25	10.00	4.44	8.50	20.00	650
624	"	"	28.75	40.19	"	"	"	"	13.75	"	"	"	"	16.41	"	"	"	"	"	"	"	"	10"FLG	10"FLG	"	"	"	"	"	775

CERTIFIED CORRECT FOR	K	REMOVED AA'	RDR 6484V	V-BELT DRIVE DATA
CUSTOMER ORDER No. _____	J	REV. DIM "H" ON 600	RDR 6294V	BMS AGP BELTS
ROOTS ORDER No. _____	H	REV. DIM "AF" ON 600	RDR 6260V	BMS AGP DRIVE SHEAVE
DATE _____	G	REV. DIM "M" ON 624	RDR 6186V	BMS DB DRIVEN SHEAVE
		REVISIONS	BY	CHANGE NOTICE
			CHKD.	APP.
				CENTER DISTANCE

400/600 SERIES  
 RAM  
 (NON-WHISPAIR) RAM

<b>DRESSER ROOTS</b>			ROOTS DIVISION DRESSER EQUIPMENT GROUP A HALLIBURTON COMPANY CONNERSVILLE, IN USA	
RDR	BMS	RDA	78390021	REV. K
DR	CHKD	APP		

PRINTED IN U.S.A.

78390A21 XXAD

## ROOTS™ RAM™ Rotary Positive Blowers

Frames 404 thru 624

**RAM™** stands for Reliability, Availability and Maintainability. Today, more than ever, ROOTS is committed to supplying our customers with reliable products manufactured with state-of-the-art CNC machine tools. Production and inventory are being scheduled and controlled to ensure these units will be available when you need them. Design improvements such as repositionable rugged steel mounting feet and die-cast aluminum drive end covers and gear covers help to reduce installation costs and make normal maintenance easier.

### BASIC BLOWER DESCRIPTION

RAM™ rotary blowers are heavy-duty units designed with integral-shaft ductile iron impellers having an involute profile. The headplates and rigid, one-piece casing are grey iron, while the drive end cover and gear cover are aluminum. Carburized and ground alloy steel spur timing gears are taper mounted on the shafts, secured with a locknut. Cylindrical roller bearings are used on all units.

Piston rings reduce air leakage through the shaft openings in the headplates, and lip-type oil seals prevent lubricant from entering the air chamber. A hydrodynamic seal on the drive shaft prevents shaft seal oil leaks.

RAM rotary blowers incorporate thrust control, with splash oil lubrication at both ends of the blower.

All frame sizes are designed with detachable rugged steel mounting feet which permit in-field adaptability to either vertical or horizontal installation requirements.

The top shaft is extended for drive on side outlet blowers, and either shaft can be extended for drive on top or bottom outlet blowers.

### WARRANTY PERIOD

Twenty-Four (24) months from date of original unit start-up or 30 months from date of original shipment, whichever occurs first.

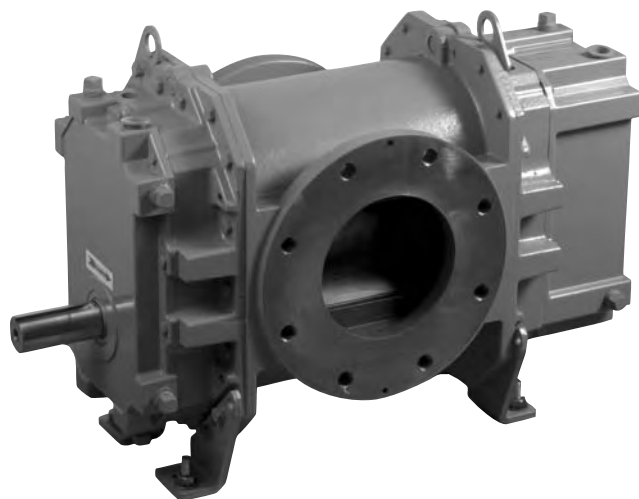

### DESIGN AND CONSTRUCTION FEATURES

1. Horizontal and vertical configurations available
2. Improved volumetric efficiency and reduced operating temperatures
3. Alloy steel timing gears
4. Cylindrical roller bearings
5. Piston ring air seals
6. Lip-type, hydrodynamic oil seals,
7. Splash oil lubrication

### OPERATING PRINCIPLE

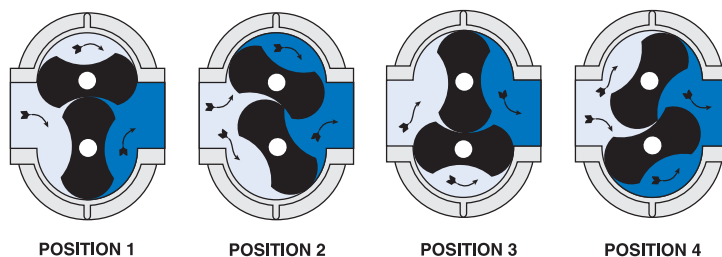

Two figure-eight lobe impellers mounted on parallel shafts rotate in opposite directions. As each impeller passes the blower inlet, it traps a definite volume of air and carries it around the case to the blower outlet, where the air is discharged. With constant speed operation the displaced volume is essentially the same regardless of pressure, temperature or barometric pressure. Timing gears control the relative position of the impellers to each other and maintain small but definite clearances. This allows operation without lubrication being required inside the air casing.

## PERFORMANCE TABLE

FRAME SIZE	SPEED RPM	4 PSI		6 PSI		8 PSI		10 PSI		12 PSI		15 PSI		18 PSI		MAX. VACUUM		
		CFM	BHP	CFM	BHP	CFM	BHP	CFM	BHP	CFM	BHP	CFM	BHP	CFM	BHP	"Hg	CFM	BHP
404	1750	149	3.6	139	5.3	130	7.0	123	8.7	116	10.4					14.0	115	5.9
	2950	281	7.0	271	9.8	262	12.6	255	15.4	248	18.2	239	22.4			15.0	240	10.9
	4000	396	8.3	386	14.2	378	17.9	370	21.6	364	25.3	355	30.9	347	37.0	16.0	353	15.9
406	1750	225	5.4	210	8.0	198	10.5	187	13.0	177	15.6					14.0	173	9.0
	2950	426	10.5	411	14.7	398	18.9	387	23.1	377	27.3	363	33.6			15.0	365	16.4
	4000	601	15.0	586	20.1	574	26.0	562	31.9	552	37.0	539	46.5	526	54.0	16.0	531	23.6
409	1750	338	8.5	315	12.0	296	15.8	279	20.0	264	23.5					14.0	259	13.5
	2950	638	15.2	615	21.5	596	27.8	579	34.1	564	40.4	544	49.8			15.0	546	24.4
	4000	900	24.0	878	30.0	859	38.1	842	46.8	827	55.0	806	67.9	788	79.0	16.0	795	35.1
412	1750	450	11.0	420	16.0	394	21.0	372	26.0	352	32.0					14.0	343	17.7
	2950	849	19.9	819	28.3	794	36.6	772	45.0	752	53.4	724	66.0			15.0	728	32.3
	4000	1199	28.8	1169	39.9	1144	51.0	1121	62.2	1101	73.3	1074	90.0			16.0	1059	46.5
418	1750	675	16.5	630	24.0	592	31.7	559	39.0							14.0	515	26.5
	2950	1275	29.5	1230	42.1	1192	54.7	1159	67.3							15.0	1092	48.4
	4000	1800	42.9	1755	59.7	1717	73.4	1684	93.1							16.0	1590	69.7
616	1170	718	16.9	672	24.9	633	32.9	599	40.9	568	49.0					13.0	579	25.9
	1750	1176	26.2	1130	38.2	1091	50.1	1056	62.0	1025	73.9					14.0	1013	42.0
	3000	2162	48.9	2116	68.7	2077	88.5	2043	108.3	2012	128.0	1970	157.7			16.0	1946	81.7
624	1170	1077	25.4	1008	37.5	950	49.5	899	61.5							13.0	869	39.0
	1750	1764	39.9	1695	57.8	1637	75.7	1585	93.6							14.0	1519	63.4
	3000	3244	77.6	3175	107.3	3117	137.0	3065	166.7							16.0	2920	124.6

**Notes:** 1. Pressure ratings based on inlet air at standard pressure of 14.7 psia, standard temperature of 68° F, and specific gravity of 1.0.  
2. Vacuum ratings based on inlet air at standard temperature of 68°F, discharge pressure of 30" Hg and specific gravity of 1.0.

## OUTLINE DRAWING & DIMENSIONAL TABLE

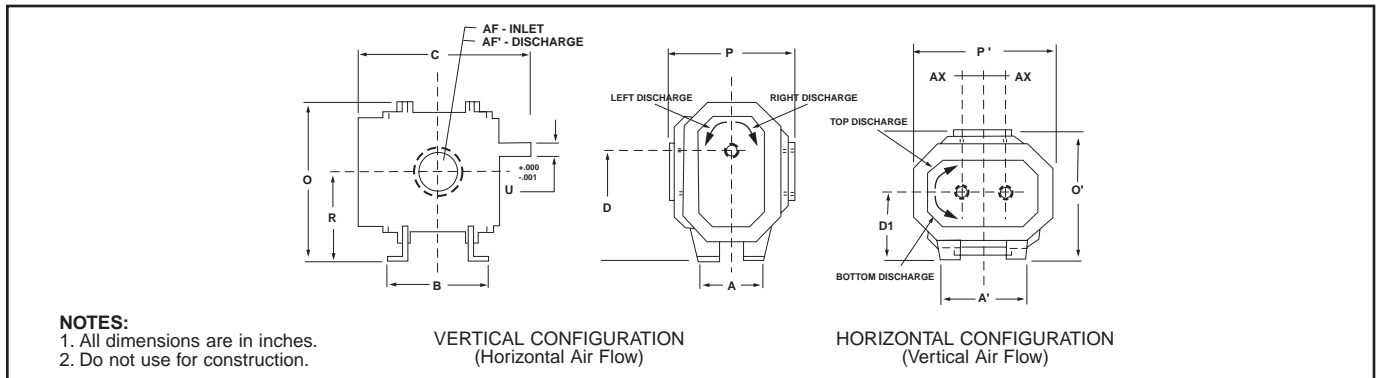

FRAME SIZE	A	A'	B	C	Drive Shaft Location		O	O'	P	P'	R	U	Keyway	AF Inlet Diameter	AF' Discharge Diameter	AX	Approx. NetWt (lbs)
					D	D1											
404	8.00	11.00	8.75	18.50	11.25	7.50	16.63	13.50	12.00	15.25	9.00	1.500	.375 x.188	3.0 NPT	3.0 NPT	2.25	200
406	8.00	11.00	10.75	20.50	11.25	7.50	16.63	13.50	12.00	15.25	9.00	1.500	.375 x.188	4.0 NPT	4.0 NPT	2.25	230
409	8.00	11.00	13.75	23.50	11.25	7.50	16.63	13.00	11.00	15.25	9.00	1.500	.375 x.188	4.0 NPT	4.0 NPT	2.25	270
412	8.00	11.00	16.75	26.50	11.25	7.50	16.63	13.00	11.00	15.25	9.00	1.500	.375 x.188	6.0 FLG	6.0 FLG	2.25	330
418	8.00	11.00	22.75	32.50	11.25	7.50	16.63	13.00	11.00	15.25	9.00	1.500	.375 x.188	8.0 FLG	8.0 FLG	2.25	410
616	10.00	16.00	20.75	32.44	15.00	9.00	22.00	16.25	14.50	20.00	12.00	2.000	.500 x.250	8.0 FLG	8.0 FLG	3.00	650
624	10.00	16.00	28.75	40.44	15.00	9.00	22.00	16.25	14.50	20.00	12.00	2.000	.500 x.250	10.0 FLG	10.0 FLG	3.00	775

**Dresser, Inc.**



**Roots**

Dresser ROOTS  
2135 Hwy 6 South  
Houston, TX 77077  
PH: 281-966-4700  
FX: 281-966-4309  
Toll Free: 1-877-363-ROOT(S)

Dresser ROOTS - Connersville  
900 West Mount Street  
Connersville, IN 47331  
PH: 765-827-9200  
FX: 765-827-9266

Dresser ROOTS - Holmes Operation  
PO Box B7  
Off St. Andrews Rd  
Turnbridge, Huddersfield  
England HD1 6RB  
PH: +44-1484-422222  
FX: +44-1484-422668

S-28F98  
February 2004

©2004 Dresser, Inc.  
ROOTS and RAM are trademarks of Dresser, Inc.  
Dresser Design is a registered trademark of Dresser, Inc.

website: [www.rootsblower.com](http://www.rootsblower.com) • email: [ROOTS@dresser.com](mailto:ROOTS@dresser.com)

**PRESSURE PERFORMANCE**  
**FRAME 409 RAM BLOWER**  
 MAXIMUM PRESSURE RISE=18 PSI \*  
 MAXIMUM SPEED=4000 RPM

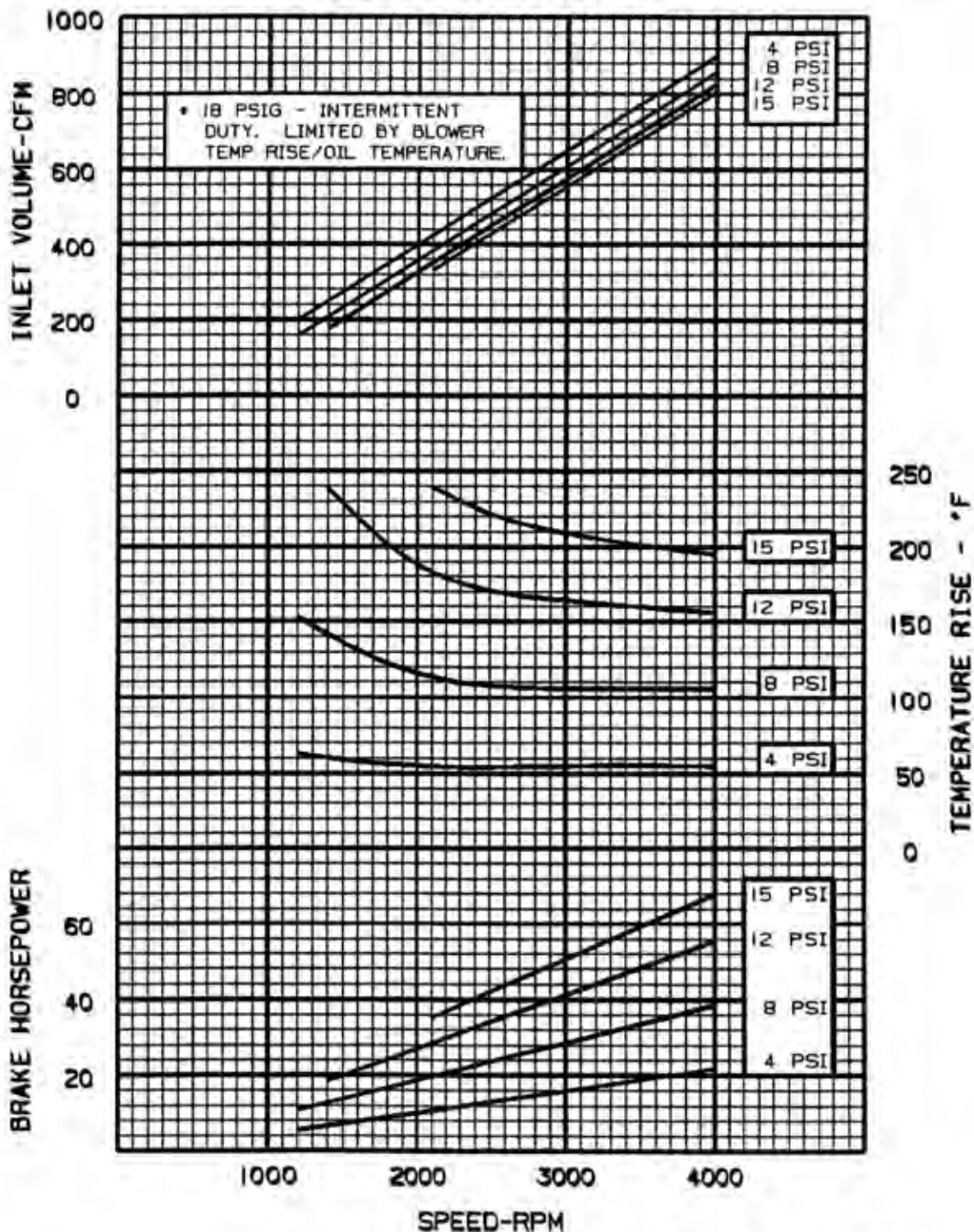



DRESSER INDUSTRIES, INC.  
**ROOTS DIVISION**  
 900 WEST MOUNT STREET  
 CONNERSVILLE, INDIANA 47331  
 PRINTED IN U.S.A.

PERFORMANCE BASED ON  
 INLET AIR = 68°F  
 DISCHARGE PRESSURE = 30" HG ABS.  
 MAY, 1997

VACUUM PERFORMANCE  
 FRAME 409 RAM BLOWER  
 MAXIMUM VACUUM=15 IN. HG  
 MAXIMUM SPEED=4000 RPM

