



Roots

624 RAM

Part Number – 85148020



- Heavy-duty unit with integral-shaft ductile iron impellers with an involute profile
- Rigid one-piece casing and headplates are grey iron
- Drive end cover and end cover are aluminum
- Carburized and ground alloy steel spur timing gears
- Cylindrical roller bearings
- Piston rings reduce air leakage
- Lip type oil seals prevent lubrication from entering the air chamber.
- Hydrodynamic seal on the drive shaft prevents oil leaks
- Splash oil lubricated gears on drive and gear ends
- Detachable steel mounting feet
- Horizontal and vertical configurations available

Also Available in:

- RAM-J (Whispair)
- RAM-GJ (Gas Whispair)
- RAM, RAM-J, RAM-GJ with Plugged Impellers
- RAM-VJ (Water Sealed Exhauster Whispair)

Equivalent to:

Tuthill M-D Equalizer RM 6024



816-741-0282



Quick Specs

Flow Range	to 3244 CFM
Max Δ Pressure	10 PSI
Max Δ Vacuum	16" Hg
Maximum RPM	3000
Minimum RPM	636
Max Δ T	230°F
Connection Size	10" Flange
Shaft Dia.	2"
Min Sheave Dia.	8.5"
Drive End Lubrication	Oil
Gear End Lubrication	Oil
Oil Sump Horiz Config	~145 oz
Oil Sump Vert Config	~83 oz
Bare Unit Weight	740 lbs
Container	Wood Skid
Skid Size (L x W x H)	54" x 32" x 36"
Shipping Weight on Skid	~790 lbs
Recommended to Ship Via	Truck



816-741-0282

**RAM™, RAM™-J Series Parts List -
4" and 6" Gear Diameter
(Refer to drawing #81881023)**

Item #	Part Name	Qty.
1	Headplate	2
3	Gearbox	1
4	Timing Gears	2
5	End Cover	1
7	Gasket – Gearbox/Cover	2
10	Shims	Lot
11	Cylinder	1
12	Impeller & Shaft Drive	1
13	Impeller & Shaft Driven	1
14	Bearing Roller	4
16	Pin, Dowel (Pull Out)	4
17	Pin, Dowel	2
19	Key Square	1
21	Breather	2
22	Plug, Pipe	12
23	Screw, Cap Hex Hd.	*
27	Seal, lip headplate	4
28	Piston, Ring-Seal	4
29	Washer, Wavy Spring	2
31	Gear Nut	2
32	Scr, Cap Hex Hd.	16
33	Seal, Lip Drive	1
34	Brg. Clamp Plate - D. E.	2
35	Lock Washer - Spring	16
37	Sight Plug - Oil Level	2
38	Sleeve, Shaft	4
40	Slinger - D.E. (Top Drive)	1
46	Slinger - G.E.	1
49	Oil Leader L/S	1
50	Oil, Leader-R/S	1
54	Brg Clamp Plate - G. E.	2
60	Screw, Cap Butt. HD.	1
64	Pin, Spring	1
66	Screw, Cap Hex HD.	*
66.1	WHISPAIR™, Spring Lock 3/8M	*
70	Shims D.E. Brg.	1
75	Screw, Cap - Hex HD.	*
76	Blower Foot - RH	2
77	Blower Foot - LH	2
85	Elb, Pipe-Black	2
85.1	Plug, Pipe	2
87	Scr, Cap BH	2
88	Anti Rotation Ball	4
90	BSHG-RDCG	2
91	Washer, Plain Flat	2
92	Washer, Plain Flat	2
93	Washer	2
94	Oil Leader	2
95	Cap Screw	4

*Quantity varies by blower.

Repair Kits

Repair kits are bundled with the parts you need to complete a standard repair. It is more cost effective to buy a repair kit than to purchase individual parts. However, if you need parts not listed in the kit, it is recommended that you call Pathfinder Systems for parts pricing.

Top, Left, or Right Drive Shaft (Bottom Shaft order P/N 854692RK)

P/N 854691RK Kit for 600 AIR RAM/RAM-J/RCS/RCS-J/DVJ/DPJ

Item	Qty	Kit Description	P/N
		ASSY Slinger 400/600	TK10002
7	2	Gasket 600 RCS Gearbox/Cover	52484021
7	2	Gasket 600 RAM Gearbox/Cover	84534021
10	1	Shim Set	52485020
14	4	Bearing, Roller	T30055020
21	2	Plug, Vent 3/8"	13005003
55	2	Breather, Mini MB Style 1/2	T20013004
27	4	Seal, Lip (Viton)	10460031
28	4	Piston, Ring Seal	12283002
29	2	Washer, Spring, Wavy	10135006
31	2	Nut, Hex ESNA 1-1/4"-12	10319018
33	1	Seal, Lip, Drive	10460038
37	2	Sight, Plug Oil Level, 3/4	12066001
38	4	Sleeve, Piston Ring	52486020
40	1	DRIVE END SLINGER	55067020
46	1	GEAR END OIL SLINGER	T20027001
60	1	CAP SCREW	12800002
70	1	Shim (0.035)	106191412
87	2	CAP SCREW	T20030001
88	4	Anti Rotation Ball	T20001001
90	2	Bushing, RDCC	11779005
91	2	PLAIN FLAT WASHER	10181004
92	2	PLAIN FLAT WASHER	10181045
93	1	GE OIL SLINGER WASHER	90181020



816-741-0282

Table 2 - Recommended Oil Grades

Ambient* Temperature °F (°C)	ISO Viscosity No.
Above 90° (32°)	320
32° to 90° (0° to 32°)	220
0° to 32° (-18° to 0°)	150
Below 0° (-18°)	100

*Ambient temperature is defined as the temperature of the space in which the blower and drive are located.

Use a good grade of **industrial type** non-detergent, rust inhibiting, anti-foaming oil and of correct viscosity per Table 2. Roots synthetic oil (Roots P/N 813-106-) is **specified and recommended**. Roots does not recommend automotive type lubricants, as they are not formulated with the properties mentioned above.

Due to sludge build-up and seal leakage problems, Roots recommendation is DO NOT USE Mobil SHC synthetic oils in ROOTS blowers.

RAM™, RAM™-J Approximate Oil Sump Capacities				
Orientation	Gearbox		Drive End	
	Fl. Oz.	Liters	Fl. Oz.	Liters
400 (Horizontal)	36	1.06	19	0.56
400 (Vertical)	18	0.52	9	0.27
600 (Horizontal)	95	2.81	50	1.48
600 (Vertical)	55	1.63	28	0.83

ROOTS® Synthetic Oil: ISO-VG-320 Grade

	Part Number
--	-------------

Quart	13106004
Gallon	13106005
Case (12 qts)	13106007

ROOTS® Synthetic Oil: ISO-VG-220 Grade

	Part Number
--	-------------

Quart	13106001
Gallon	13106002
Case (12 qts)	13106008

ROOTS® Synthetic Oil: ISO-VG-150 Grade

	Part Number
--	-------------

Quart	13106020
Gallon	13106021
Case (12 qts)	13106023
5 Gallon Pail	13106022
55 Gallon Drum	13106025

ROOTS® Synthetic Oil: ISO-VG-100 Grade

	Part Number
--	-------------

Quart	13106011
Gallon	13106012
Case (12 qts)	13106014
5 Gallon Pail	13106013
55 Gallon Drum	13106016

NOTES:

1. DRIVE END COVER TO BE PINNED TO HEADPLATE AFTER ALIGNING SEAL BORE WITH SHAFT WITHIN .001
2. USE TEFLON SEALANT ON ALL PIPE THREADS & CYLINDER TO HEADPLATE FLANGE FOR WHISPAIR GAS PUMP UNITS ONLY.
3. ITEMS 34 & 54 MUST BE INSTALLED WITH OIL GROOVE AT TOP.
4. TORQUE TO 400 FT.LBS. -400
TORQUE TO 630 FT.LBS. -600
5. TORQUE TO 75 FT.LBS. -400
TORQUE TO 140 FT.LBS. -600
APPLY LOCKTITE TO SCREW THREADS & BOTH FACES OF WASHER & SLINGER.
6. TORQUE TO 35 FT.LBS. (HEADPLATE)
7. TORQUE TO 10 FT.LBS. (GEARBOX/END COVER)
8. LOCKTIGHT AND TORQUE TO FT.LBS. -75
9. TWO 1/2 X 3/4 BUSHINGS FOR BREATHERS ON 600 RAM SERIES ONLY

BOTTOM DRIVE OPTION
ALSO SHOWN AS GAS SERVICE

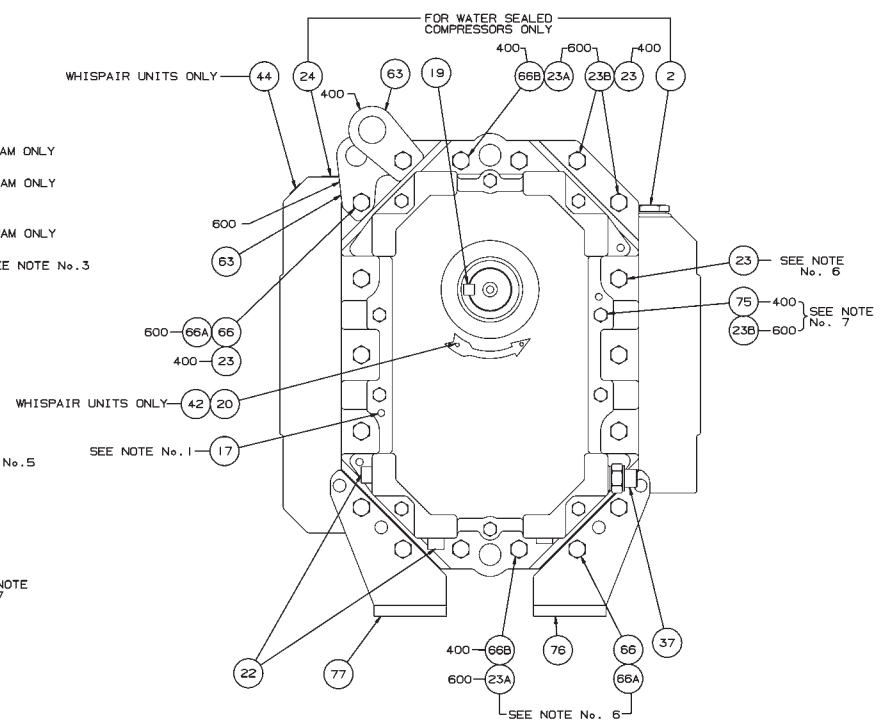
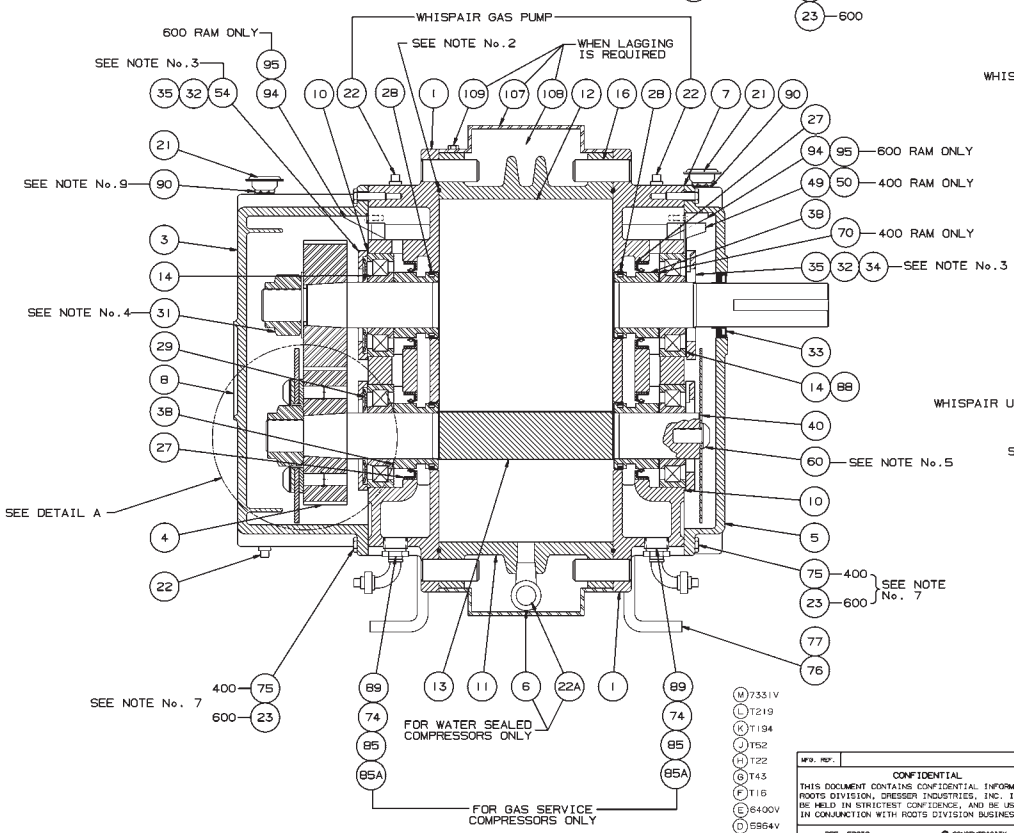
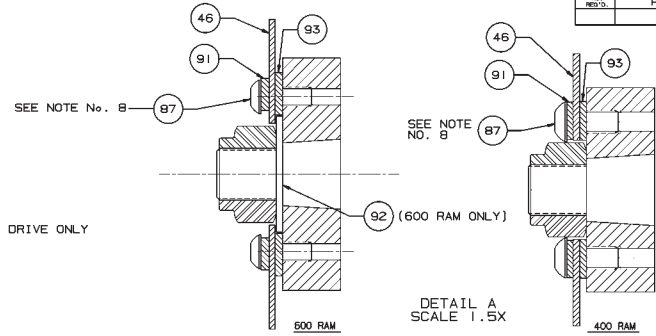
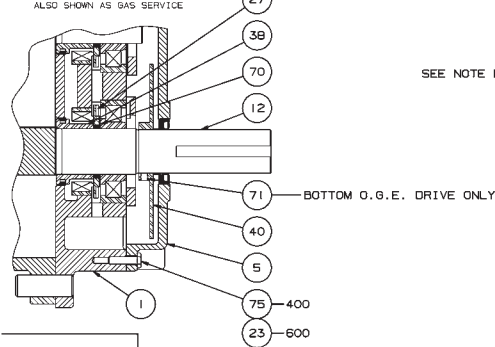

- (M) 7331V
- (L) T219
- (K) T194
- (J) T52
- (H) T22
- (G) T43
- (F) T16
- (E) 6400V
- (D) 5964V
- (C) 5757V
- (B) 5560V
- (A) 5048V

REV.	DESCRIPTION	DATE	BY	CHKD.	APP.
S	BOTT. DRIVE OPTION SLINGER REVERSED	7/18/67	DAB	B203V	
R	REVISED GEAR END SLINGERS	1-26-68	AMP	7654V	
G	ADDED NOTE TO ITEM 50 & 70	9-1-68	AMP	7591V	RCA
B	MOVED LIFTING LUG	1-15-69	AMP	7430V	RCA
D	ADDED BSB	3/8/69	RGR	7412V	RCA
N	ADDED LAGSINS	2/2/69	YC	7331V	RCA

RAM/RAM-J/RAM-GJ/RAM-VJ
400/600 RAM

SECTIONAL ASSEMBLY

81881023

REV S

Assembly of RAM Series - Air & Gas Blowers

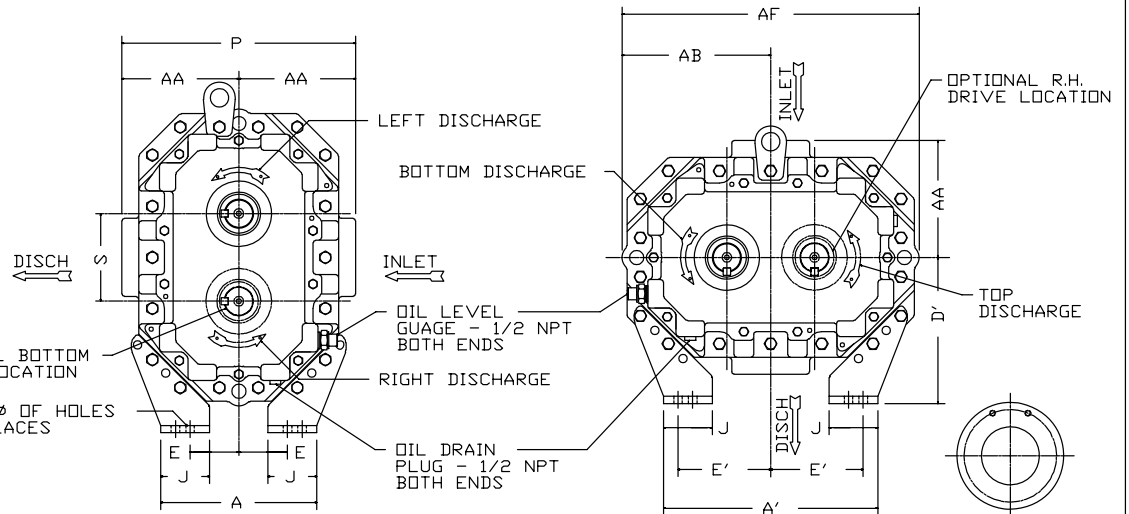
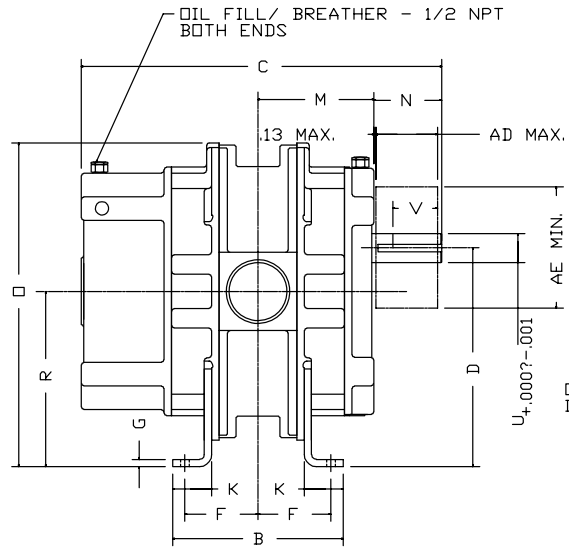

W - INLET
 W' - DISCHARGE
 AD - MAXIMUM SHEAVE WIDTH
 (SEE OVERHUNG LOAD LIMIT K-24102)
 AE - MINIMUM SHEAVE DIAMETER
 (SEE OVERHUNG LOAD LIMIT K-24102)
 ALL DIMENSIONS IN INCHES

INLET & DISCHARGE FLANGES TO MATE FLUSH & SQUARE WITH FLAT FACE FLANGE ONLY. USE FULL FACE GASKETS.
 V-BELT DRIVEN UNITS: MOTOR TO BE LOCATED ON INLET SIDE OF BLOWER.

A 5048V B 5048V C 5560V D 5767V
 E 5986V F 6006V

FLG	5"	6"	8"	10"
OPENING	5"	6"	8"	10"
BOLT CIRCLE	8.50	9.50	11.75	14.25
FLANGE O.D.	10.00	11.00	13.50	16.00
No TAPPED HOLES	8	8	8	12
SIZE HOLES	3/4-10	3/4-10	3/4-10	7/8-9
TAP DEPTH	1.13	1.13	1.13	1.13

FRAME SIZE	A	A'	B	C	D	D'	E	E'	F	G	H	J	K	M	N	O	P	R	S	U	V	KEYWAY	W	W'	AA	AB	AD	AE	AF	APPROX WEIGHT
404	8.00	11.00	8.75	18.50	11.25	7.50	2.50	4.75	3.75	.38	.44	2.50	2.00	5.95	3.48	16.63	12.00	9.00	4.50	1.50	2.75	.375X.188	3"NPT	3"NPT	6.00	7.63	3.06	7.10	15.25	230
406	"	"	10.75	20.50	"	"	"	"	4.75	"	"	"	"	6.95	"	"	"	"	"	"	"	"	4"NPT	4"NPT	"	"	"	"	"	260
409	"	"	13.75	23.50	"	"	"	"	6.25	"	"	"	"	8.45	"	"	11.00	"	"	"	"	"	"	"	5.50	"	"	"	"	300
412	"	"	16.75	26.50	"	"	"	"	7.75	"	"	"	"	9.95	"	"	"	"	"	"	"	"	6"FLG	6"FLG	"	"	"	"	"	360
418	"	"	22.75	32.50	"	"	"	"	10.75	"	"	"	"	12.95	"	"	"	"	"	"	"	"	8"FLG	8"FLG	"	"	"	"	"	440
616	9.00	15.00	20.75	32.19	15.00	9.00	3.50	6.50	9.75	.38	.56	2.50	2.00	12.41	4.30	22.00	14.50	12.00	6.00	2.00	3.63	.500x.250	8"FLG	8"FLG	7.25	10.00	4.44	8.50	20.00	650
624	"	"	28.75	40.19	"	"	"	"	13.75	"	"	"	"	16.41	"	"	"	"	"	"	"	"	10"FLG	10"FLG	"	"	"	"	"	775

CERTIFIED CORRECT FOR
 CUSTOMER ORDER No. _____
 ROOTS ORDER No. _____
 DATE _____

REVISIONS	BY	CHANGE NOTICE	CHKD.	APP.
K		REMOVED AA'		
J		REV. DIM "H" ON 600		
H		REV. DIM "AF" ON 600		
G		REV. DIM "M" ON 624		

V-BELT DRIVE DATA
400/600 SERIES
RAM
 (NON-WHISPAIR) RAM

DRESSER ROOTS			ROOTS DIVISION DRESSER EQUIPMENT GROUP A HALLIBURTON COMPANY CONNERSVILLE, IN USA	
RDR	BMS	RDA	78390021	REV. K
DR	CHKD	APP		

PRINTED IN U.S.A.

78390A21 XXAD

ROOTS™ RAM™ Rotary Positive Blowers

Frames 404 thru 624

RAM™ stands for Reliability, Availability and Maintainability. Today, more than ever, ROOTS is committed to supplying our customers with reliable products manufactured with state-of-the-art CNC machine tools. Production and inventory are being scheduled and controlled to ensure these units will be available when you need them. Design improvements such as repositionable rugged steel mounting feet and die-cast aluminum drive end covers and gear covers help to reduce installation costs and make normal maintenance easier.

BASIC BLOWER DESCRIPTION

RAM™ rotary blowers are heavy-duty units designed with integral-shaft ductile iron impellers having an involute profile. The headplates and rigid, one-piece casing are grey iron, while the drive end cover and gear cover are aluminum. Carburized and ground alloy steel spur timing gears are taper mounted on the shafts, secured with a locknut. Cylindrical roller bearings are used on all units.

Piston rings reduce air leakage through the shaft openings in the headplates, and lip-type oil seals prevent lubricant from entering the air chamber. A hydrodynamic seal on the drive shaft prevents shaft seal oil leaks.

RAM rotary blowers incorporate thrust control, with splash oil lubrication at both ends of the blower.

All frame sizes are designed with detachable rugged steel mounting feet which permit in-field adaptability to either vertical or horizontal installation requirements.

The top shaft is extended for drive on side outlet blowers, and either shaft can be extended for drive on top or bottom outlet blowers.

WARRANTY PERIOD

Twenty-Four (24) months from date of original unit start-up or 30 months from date of original shipment, whichever occurs first.



DESIGN AND CONSTRUCTION FEATURES

1. Horizontal and vertical configurations available
2. Improved volumetric efficiency and reduced operating temperatures
3. Alloy steel timing gears
4. Cylindrical roller bearings
5. Piston ring air seals
6. Lip-type, hydrodynamic oil seals,
7. Splash oil lubrication

OPERATING PRINCIPLE

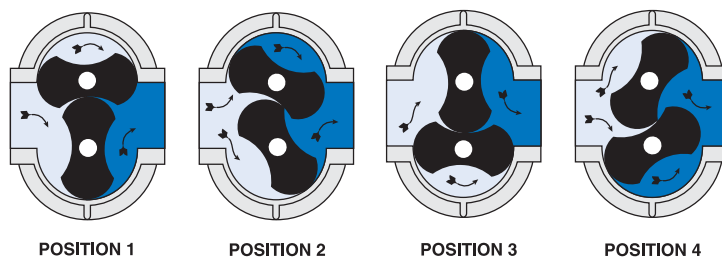

Two figure-eight lobe impellers mounted on parallel shafts rotate in opposite directions. As each impeller passes the blower inlet, it traps a definite volume of air and carries it around the case to the blower outlet, where the air is discharged. With constant speed operation the displaced volume is essentially the same regardless of pressure, temperature or barometric pressure. Timing gears control the relative position of the impellers to each other and maintain small but definite clearances. This allows operation without lubrication being required inside the air casing.



PERFORMANCE TABLE

FRAME SIZE	SPEED RPM	4 PSI		6 PSI		8 PSI		10 PSI		12 PSI		15 PSI		18 PSI		MAX. VACUUM		
		CFM	BHP	CFM	BHP	CFM	BHP	CFM	BHP	CFM	BHP	CFM	BHP	CFM	BHP	"Hg	CFM	BHP
404	1750	149	3.6	139	5.3	130	7.0	123	8.7	116	10.4					14.0	115	5.9
	2950	281	7.0	271	9.8	262	12.6	255	15.4	248	18.2	239	22.4			15.0	240	10.9
	4000	396	8.3	386	14.2	378	17.9	370	21.6	364	25.3	355	30.9	347	37.0	16.0	353	15.9
406	1750	225	5.4	210	8.0	198	10.5	187	13.0	177	15.6					14.0	173	9.0
	2950	426	10.5	411	14.7	398	18.9	387	23.1	377	27.3	363	33.6			15.0	365	16.4
	4000	601	15.0	586	20.1	574	26.0	562	31.9	552	37.0	539	46.5	526	54.0	16.0	531	23.6
409	1750	338	8.5	315	12.0	296	15.8	279	20.0	264	23.5					14.0	259	13.5
	2950	638	15.2	615	21.5	596	27.8	579	34.1	564	40.4	544	49.8			15.0	546	24.4
	4000	900	24.0	878	30.0	859	38.1	842	46.8	827	55.0	806	67.9	788	79.0	16.0	795	35.1
412	1750	450	11.0	420	16.0	394	21.0	372	26.0	352	32.0					14.0	343	17.7
	2950	849	19.9	819	28.3	794	36.6	772	45.0	752	53.4	724	66.0			15.0	728	32.3
	4000	1199	28.8	1169	39.9	1144	51.0	1121	62.2	1101	73.3	1074	90.0			16.0	1059	46.5
418	1750	675	16.5	630	24.0	592	31.7	559	39.0							14.0	515	26.5
	2950	1275	29.5	1230	42.1	1192	54.7	1159	67.3							15.0	1092	48.4
	4000	1800	42.9	1755	59.7	1717	73.4	1684	93.1							16.0	1590	69.7
616	1170	718	16.9	672	24.9	633	32.9	599	40.9	568	49.0					13.0	579	25.9
	1750	1176	26.2	1130	38.2	1091	50.1	1056	62.0	1025	73.9					14.0	1013	42.0
	3000	2162	48.9	2116	68.7	2077	88.5	2043	108.3	2012	128.0	1970	157.7			16.0	1946	81.7
624	1170	1077	25.4	1008	37.5	950	49.5	899	61.5							13.0	869	39.0
	1750	1764	39.9	1695	57.8	1637	75.7	1585	93.6							14.0	1519	63.4
	3000	3244	77.6	3175	107.3	3117	137.0	3065	166.7							16.0	2920	124.6

Notes: 1. Pressure ratings based on inlet air at standard pressure of 14.7 psia, standard temperature of 68° F, and specific gravity of 1.0.
2. Vacuum ratings based on inlet air at standard temperature of 68°F, discharge pressure of 30" Hg and specific gravity of 1.0.

OUTLINE DRAWING & DIMENSIONAL TABLE

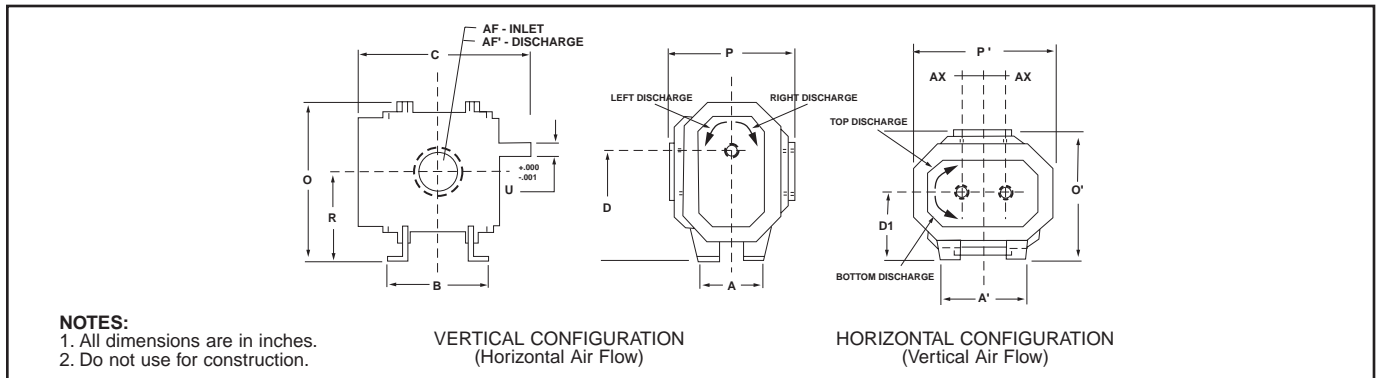

FRAME SIZE	A	A'	B	C	Drive Shaft Location		O	O'	P	P'	R	U	Keyway	AF Inlet Diameter	AF' Discharge Diameter	AX	Approx. NetWt (lbs)
					D	D1											
404	8.00	11.00	8.75	18.50	11.25	7.50	16.63	13.50	12.00	15.25	9.00	1.500	.375 x.188	3.0 NPT	3.0 NPT	2.25	200
406	8.00	11.00	10.75	20.50	11.25	7.50	16.63	13.50	12.00	15.25	9.00	1.500	.375 x.188	4.0 NPT	4.0 NPT	2.25	230
409	8.00	11.00	13.75	23.50	11.25	7.50	16.63	13.00	11.00	15.25	9.00	1.500	.375 x.188	4.0 NPT	4.0 NPT	2.25	270
412	8.00	11.00	16.75	26.50	11.25	7.50	16.63	13.00	11.00	15.25	9.00	1.500	.375 x.188	6.0 FLG	6.0 FLG	2.25	330
418	8.00	11.00	22.75	32.50	11.25	7.50	16.63	13.00	11.00	15.25	9.00	1.500	.375 x.188	8.0 FLG	8.0 FLG	2.25	410
616	10.00	16.00	20.75	32.44	15.00	9.00	22.00	16.25	14.50	20.00	12.00	2.000	.500 x.250	8.0 FLG	8.0 FLG	3.00	650
624	10.00	16.00	28.75	40.44	15.00	9.00	22.00	16.25	14.50	20.00	12.00	2.000	.500 x.250	10.0 FLG	10.0 FLG	3.00	775

Dresser, Inc.



Roots

Dresser ROOTS
2135 Hwy 6 South
Houston, TX 77077
PH: 281-966-4700
FX: 281-966-4309
Toll Free: 1-877-363-ROOT(S)

Dresser ROOTS - Connersville
900 West Mount Street
Connersville, IN 47331
PH: 765-827-9200
FX: 765-827-9266

Dresser ROOTS - Holmes Operation
PO Box B7
Off St. Andrews Rd
Turnbridge, Huddersfield
England HD1 6RB
PH: +44-1484-422222
FX: +44-1484-422668

S-28F98
February 2004

©2004 Dresser, Inc.
ROOTS and RAM are trademarks of Dresser, Inc.
Dresser Design is a registered trademark of Dresser, Inc.

website: www.rootsblower.com • email: ROOTS@dresser.com

DRESSER INDUSTRIES INC.
ROOTS DIVISION
 900 WEST MOUNT STREET
 CONNERSVILLE, INDIANA 47331
 PRINTED IN U.S.A.

PERFORMANCE BASED ON AIR,
 INLET AT 14.7 PSIA & 68°F
 AUGUST, 1998

PRESSURE PERFORMANCE
FRAME 624 RAM BLOWER
 MAX. PRESSURE RISE = 10 PSI
 MAX. SPEED = 3000 RPM

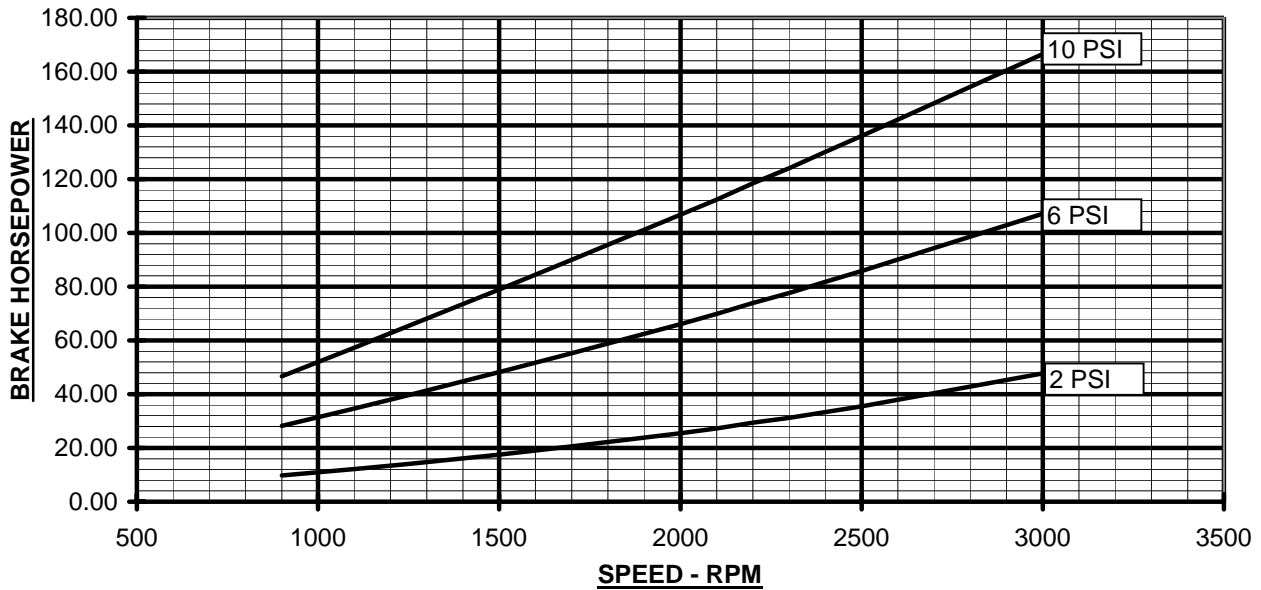
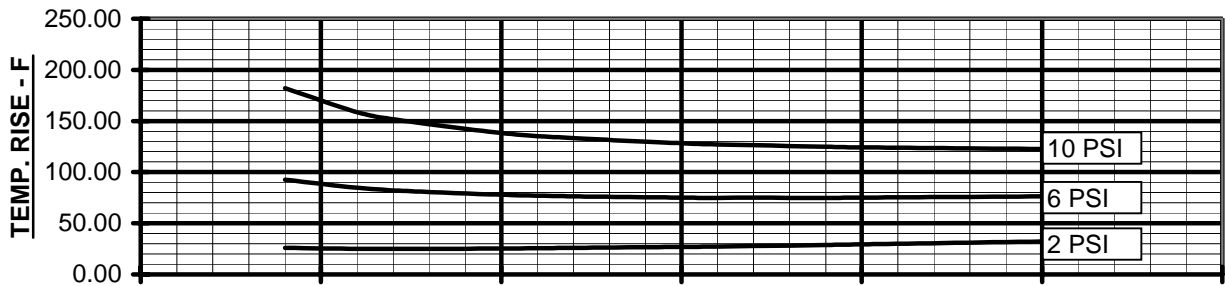
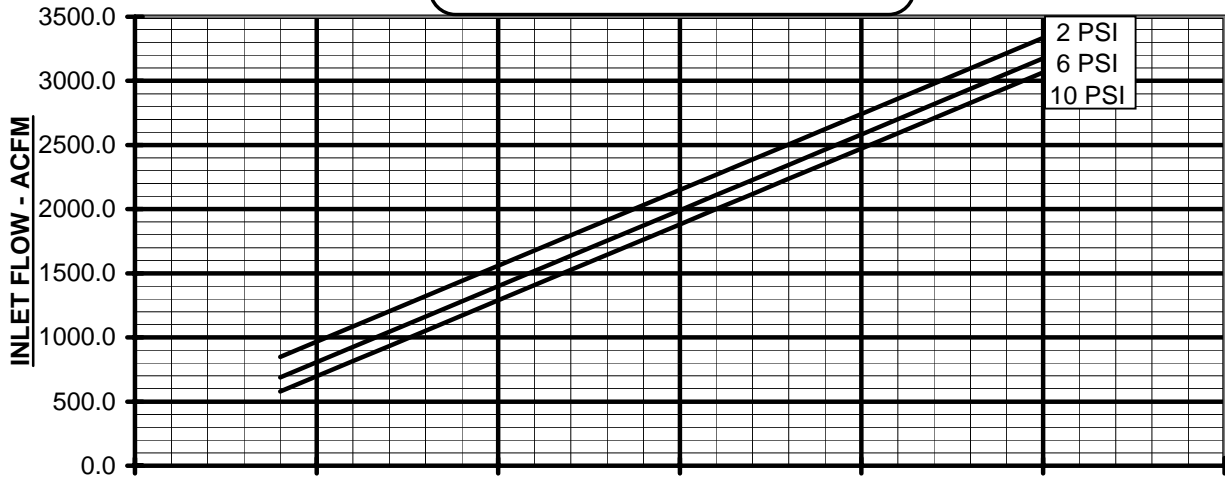

DRESSER INDUSTRIES INC.
ROOTS DIVISON
 900 WEST MOUNT STREET
 CONNERSVILLE, INDIANA 47331
 PRINTED IN U.S.A.

PERFORMANCE BASED ON AIR,
 INLET AT 68° F, DISCH. AT 30" HGA
 AUGUST, 1998

VACUUM PERFORMANCE
FRAME 624 RAM BLOWER
 MAX. VACUUM = 15" HG
 MAX. SPEED = 3000 RPM

