



Roots
624 RAM-VJ

Part Number – call 816-741-0282



Patented WHISPAIR™ Water Sealed Vacuum Exhausters have an inlet spray nozzle and seal water flow meter for water injection. It is designed to handle a limited quantity of liquid without damage. This permits introduction of sealing water at the blower inlet to improve operating efficiency and reduce internal temperature rise.

WHISPAIR blowers reduce noise and power loss by utilizing an exclusive wrap-around plenum and proprietary WHISPAIR jet to control pressure equalization-feeding backflow in the direction of impeller movement, thereby aiding rotation. This design results in longer bearing life, lower vibration, and reduces noise up to 5 dBA pressure or vacuum.

- Heavy-duty unit with integral-shaft ductile iron impellers with an involute profile
- Rigid one-piece casing and headplates are grey iron
- Drive end cover and end cover are aluminum
- Carburized and ground alloy steel spur timing gears
- Cylindrical roller bearings
- Piston rings reduce air leakage
- Lip type oil seals prevent lubrication from entering the air chamber.
- Splash oil lubricated gears on drive and gear ends
- Detachable steel mounting feet
- Horizontal and vertical configurations available



816-741-0282



Quick Specs

Maximum Recommended Sealing Water Flow Rate – Includes injected and process water (single or two stage operation)	6 Gallons/Min
Flow Range	to 2350 CFM
Max ΔVacuum	16" Hg
Maximum RPM	2400
Minimum RPM	1750
Max ΔT	200°F
Inlet Connection Size	10" Flange
Discharge Connection Size	8" Flange
Shaft Dia.	2"
Min Sheave Dia.	8.5"
Drive End Lubrication	Oil
Gear End Lubrication	Oil
Oil Sump Horiz Config	N/A
Oil Sump Vert Config	~96 oz
Bare Unit Weight	1000 lbs
Container	Wood Skid
Skid Size (L x W x H)	54" x 32" x 36"
Shipping Weight on Skid	~1050 lbs
Recommended to Ship Via	Truck



816-741-0282

**RAM series parts list 4" & 6" gear diameter
for Gas, DVJ, DPJ & JV**
(Refer to drawing #81881023)

Item #	Part Name	Qty.
1	Headplate	2
2	Spray nozzle assembly	1
3	Gearbox	1
4	Timing Gears	2
5	End Cover	1
7	Gasket – Gearbox/Cover	2
10	Shims	Lot
11	Cylinder	1
12	Impeller & Shaft Drive	1
13	Impeller & Shaft Driven	1
14	Bearing Roller	4
16	Pin, Dowel (Pull Out)	4
17	Pin, Dowel	2
19	Key Square	1
21	Plug - Vent	2
22	Plug, Pipe	12
23	Screw, Cap Hex Hd.	*
27	Seal, Lip Headplate DVJ, DPJ, VJ	4
27	Seal-Mech-Viton Gas	4
28	Piston, Ring-Seal	4
29	Washer, Wavy Spring	2
31	Gear Nut	2
32	Scr, Cap Hex Hd.	16
33	Seal, Lip Drive	1
34	Brg. Clamp Plate - D. E.	2
35	Lock Washer - Spring	16
37	Oil Level Gauge	2
38	Sleeve, Shaft DVJ, DPJ, JV	4
38	Sleeve - Gas	4
40	Slinger - D.E. (Top Drive)	1
46	Slinger - G.E.	1
49	Oil Leader L/S	1
50	Oil, Leader-R/S	1
54	Brg Clamp Plate - G. E.	2
60	Screw, Cap Butt. HD.	1
64	Pin, Spring	1
66	Screw, Cap Hex HD.	*
66.1	Whispair, Spring Lock 3/8M	*
70	Shims D.E. Brg.	1
75	Screw, Cap - Hex HD.	*
76	Blower Foot - RH	2
77	Blower Foot - LH	2
85	Elb, Pipe-Black	2
85.1	Plug, Pipe	2
87	Scr, Cap BH	2
88	Anti Rotation Ball	4
90	BSHG-RDCG	2
91	Washer, Plain Flat	2
92	Washer, Plain Flat	2
93	Washer	2
94	Oil Leader	2
95	Cap Screw	4

**Repair Kit
Call 816-741-0282**

Specified Lubricants

**ROOTS Synthetic Oil:
ISO-VG-320 Grade**

	Part Number
Quart	13106004
Gallon	13106005
Case (12 qts)	13106007

**ROOTS Synthetic Oil:
ISO-VG-220 Grade**

	Part Number
Quart	13106001
Gallon	13106002
Case (12 qts)	13106008

**ROOTS Synthetic Oil:
ISO-VG-150 Grade**

	Part Number
Quart	13106020
Gallon	13106021
Case (12 qts)	13106023
5 Gallon Pail	13106022
55 Gallon Drum	13106025

**ROOTS Synthetic Oil:
ISO-VG-100 Grade**

	Part Number
Quart	13106011
Gallon	13106012
Case (12 qts)	13106014
5 Gallon Pail	13106013
55 Gallon Drum	13106016

NOTES:

1. DRIVE END COVER TO BE PINNED TO HEADPLATE AFTER ALIGNING SEAL BORE WITH SHAFT WITHIN .001
2. USE TEFLON SEALANT ON ALL PIPE THREADS & CYLINDER TO HEADPLATE FLANGE FOR WHISPAIR GAS PUMP UNITS ONLY.
3. ITEMS 34 & 54 MUST BE INSTALLED WITH OIL GROOVE AT TOP.
4. TORQUE TO 400 FT.LBS. -400
TORQUE TO 630 FT.LBS. -600
5. TORQUE TO 75 FT.LBS. -400
TORQUE TO 140 FT.LBS. -600
APPLY LOCKTITE TO SCREW THREADS & BOTH FACES OF WASHER & SLINGER.
6. TORQUE TO 35 FT.LBS. (HEADPLATE)
7. TORQUE TO 10 FT.LBS. (GEARBOX/END COVER)
8. LOCKTIGHT AND TORQUE TO FT.LBS. -75
9. TWO 1/2 X 3/4 BUSHINGS FOR BREATHERS ON 600 RAM SERIES ONLY

BOTTOM DRIVE OPTION

ALSO SHOWN AS GAS SERVICE

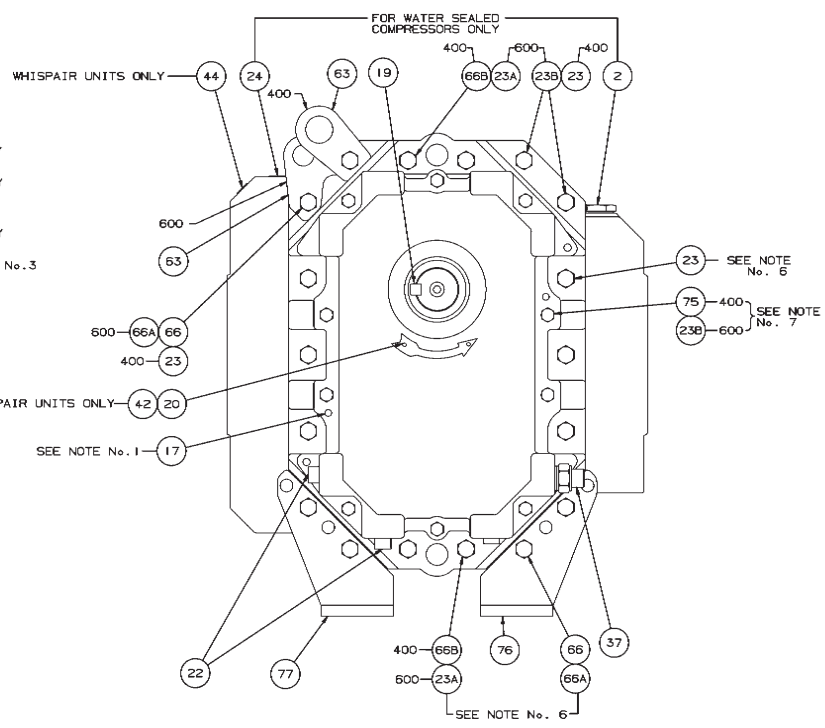
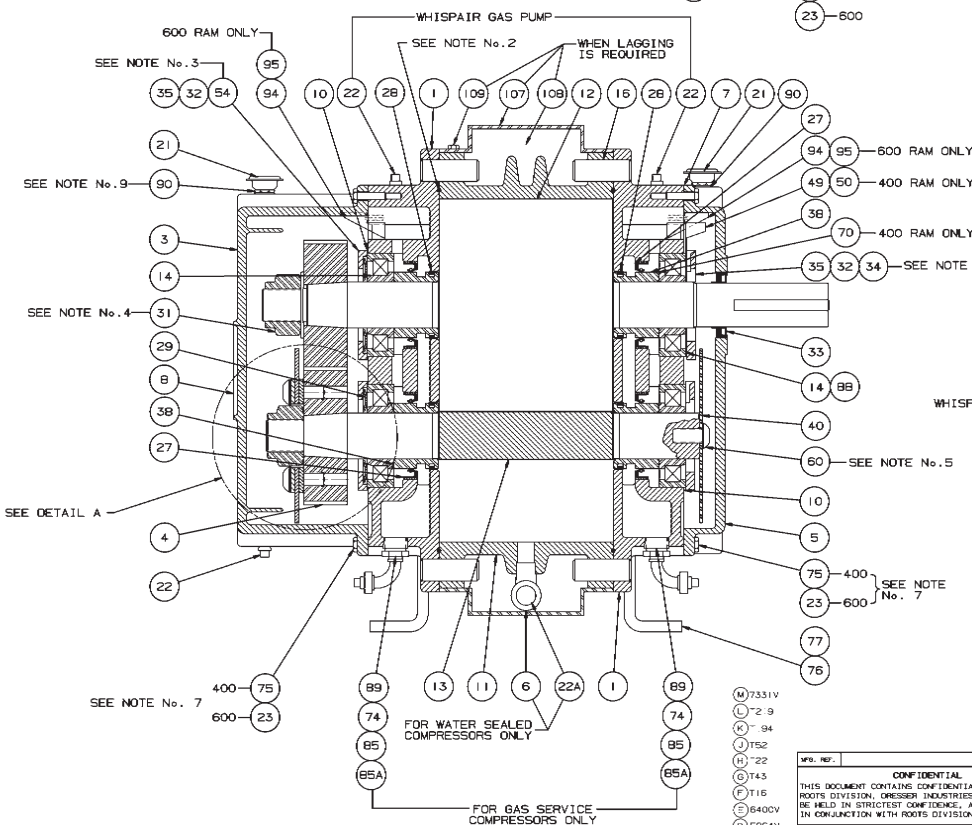
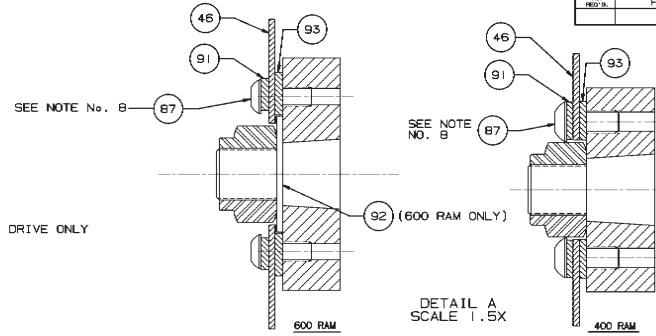
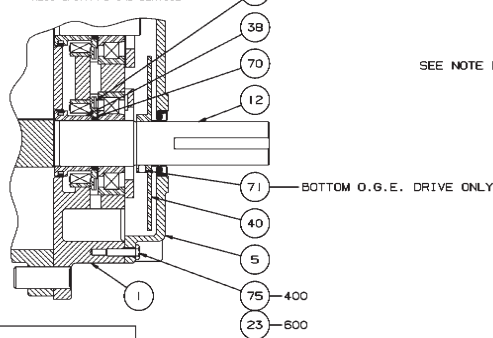

- (M) 7331V
- (L) 2-9
- (K) 94
- (J) T52
- (H) 22
- (G) T43
- (F) T16
- (E) 6400V
- (D) 5964V
- (C) 5767V
- (B) 5950V
- (A) 5C45V

REV.	DATE	BY	CHKD.	APP.	DATE	REV.	DATE	BY	CHKD.	APP.
5	1/20/98	DAB	TH/ECT		1/20/98	1	1/20/98	DRP		
4	1/20/98	AMP			1/20/98	2	1/20/98	DRP		
3	1/20/98	AMP			1/20/98	3	1/20/98	DRP		
2	1/20/98	AMP			1/20/98	4	1/20/98	DRP		
1	1/20/98	AMP			1/20/98	5	1/20/98	DRP		

Assembly of RAM Series - Air & Gas Blowers

REV. NO.	PART NAME	REV. NO.	MAT'L.

RAM/RAM-J/RAM-GJ/RAM-VJ
SECTIONAL ASSEMBLY
430/630 RAM

DO NOT SCALE FOR DIMENSIONS
ALL DIMENSIONS ARE IN INCHES UNLESS SPECIFIED OTHERWISE

DRESSER
Roots

Dresser, Roots & Dresser, Inc.
HOUSTON, TX USA

81881023
REV S

OIL FILL/ BREATHER
1/2 NPT
BOTH ENDS

VENT PURGE CONN. - 1/2 NPT
BOTH ENDS
(WHISPAIR GAS PUMP ONLY)

1/2 NPT CONNECTION
SEAL WATER
4.5 G.P.M. MAX
(WHISPAIR WATER SEALED
VAC. PUMP ONLY)

No. REQ'D.	PART NAME	PATT. No. PART No.	MAT'L.
------------	-----------	--------------------	--------

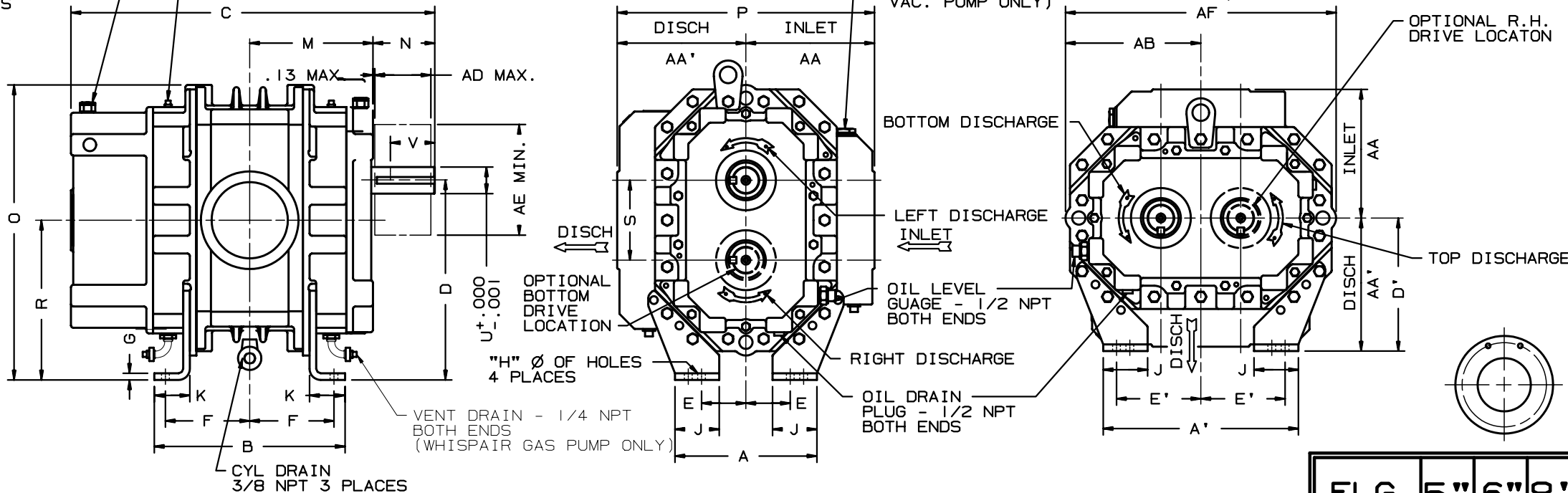

W - INLET
W' - DISCHARGE
AD - MAXIMUM SHEAVE WIDTH
(SEE OVERHUNG LOAD LIMIT K-24102)
AE - MINIMUM SHEAVE DIAMETER
(SEE OVERHUNG LOAD LIMIT K-24102)
ALL DIMENSIONS IN INCHES

INLET & DISCHARGE FLANGES TO
MATE FLUSH & SQUARE WITH
FLAT FACE FLANGE ONLY.
USE FULL FACE GASKETS.
V-BELT DRIVEN UNITS: MOTOR
TO BE LOCATED ON INLET SIDE
OF BLOWER.

A 5048V C 5420V D 5560V E 5767V
F 5986V

FLG	5"	6"	8"	10"
OPENING	5"	6"	8"	10"
BOLT CIRCLE	8.50	9.50	11.75	14.25
FLANGE O.D.	10.00	11.00	13.50	16.00
No TAPPED HOLES	8	8	8	12
SIZE HOLES	3/4-10	3/4-10	3/4-10	7/8-9
TAP DEPTH	1.13	1.13	1.13	1.13

FRAME SIZE	A	A'	B	C	D	D'	E	E'	F	G	H	J	K	M	N	O	P	R	S	U	V	KEYWAY	W	W'	INLET AA	DISCH AA'	AB	AD	AE	AF	APPROX WEIGHT
404	8.00	11.00	8.75	18.50	11.25	7.50	2.50	4.75	3.75	.38	.44	2.50	2.00	5.95	3.48	16.63	14.50	9.00	4.50	1.50	2.75	.375x.188	3"NPT	3"NPT	7.25	7.25	7.63	3.06	7.10	15.25	260
406	"	"	10.75	20.50	"	"	"	"	4.75	"	"	"	"	6.95	"	"	"	"	"	"	"	"	4"NPT	4"NPT	"	"	"	"	"	"	300
409	"	"	13.75	23.50	"	"	"	"	6.25	"	"	"	"	8.45	"	"	"	"	"	"	"	"	5"NPT	5"NPT	"	"	"	"	"	"	350
412	"	"	16.75	26.50	"	"	"	"	7.75	"	"	"	"	9.95	"	"	13.00	"	"	"	"	"	6"FLG	5"FLG	6.00	7.00	"	"	"	"	400
418	"	"	22.75	32.50	"	"	"	"	10.75	"	"	"	"	12.95	"	"	14.00	"	"	"	"	"	8"FLG	6"FLG	7.00	"	"	"	"	"	500
616	9.00	15.00	20.75	32.19	15.00	9.00	3.50	6.50	9.75	.38	.56	2.50	2.00	12.41	4.30	22.00	16.25	12.00	6.00	2.00	3.63	.500x.250	8"FLG	6"FLG	7.50	8.75	10.00	4.44	8.50	20.00	700
624	"	"	28.75	40.19	"	"	"	"	13.75	"	"	"	"	16.41	"	"	17.50	"	"	"	"	"	10"FLG	8"FLG	8.75	"	"	"	"	"	910

MFG. REF.											DATE	DO NOT SCALE FOR DIMENSIONS ALL DIMENSIONS SHOWN IN BRACKETS [] ARE MILLIMETERS										ORDER No.								
CONFIDENTIAL															DR. RDR	<h2 style="text-align: center;">400/600 SERIES RAM</h2> <p style="text-align: center;">(WHISPAIR) RAM-J/RAM-GJ & RAM-VJ</p>														
THIS DOCUMENT CONTAINS CONFIDENTIAL INFORMATION OF ROOTS DIVISION, DRESSER INDUSTRIES, INC. IT SHALL BE HELD IN STRICTEST CONFIDENCE, AND BE USED ONLY IN CONJUNCTION WITH ROOTS DIVISION BUSINESS.															CHKD. BMS															
REF: EP938															APP. RDA	<p style="text-align: right;">ROOTS DIVISION DRESSER, INC. HOUSTON, TX USA</p>														
<ul style="list-style-type: none"> □ FLATNESS ∠ ANGULARITY // PARALLELISM ⊕ TRUE POSITION — STRAIGHTNESS 															DBV															
<ul style="list-style-type: none"> ⊙ CONCENTRICITY ⊥ PERPENDICULARITY — PROFILE OF LINE ⌒ PROFILE OF A SURFACE ∅ DIAMETER ✓ FINISH IN MICRO INCHES 															SCALE	<p style="text-align: center;">DIMENSIONAL TOLERANCES UNLESS OTHERWISE SPECIFIED</p> <p style="text-align: center;">FINISHED DIMENSIONS</p> <p style="text-align: center;">TWO PLACE DECIMALS (.XX)---±.015 FRACTIONAL---±1/64</p> <p style="text-align: center;">THREE PLACE DECIMALS (.XXX)---±.005</p>														
REVISIONS															BY	DATE	CHANGE NOTICE	CHKD.	APP	78389021										REV L

**ROOTS™ RAM™ -VJ WHISPAIR™
Water-sealed Vacuum Exhausters**

Frames 406J, thru 624J

RAM™ stands for Reliability, Availability and Maintainability. Today, more than ever, ROOTS is committed to supplying our customers with reliable products manufactured with state-of-the-art CNC machine tools. Production and inventory are being scheduled and controlled to ensure these units will be available when you need them. Design improvements such as repositionable rugged steel mounting feet and die-cast aluminum drive end covers and gear covers help to reduce installation costs and make normal maintenance easier.

BASIC BLOWER DESCRIPTION

ROOTS™ RAM™ WHISPAIR™ water-sealed vacuum exhausters are heavy-duty units designed with integral-shaft ductile iron impellers. Whispair vacuum exhausters reduce noise and power loss by utilizing an exclusive wrap-around plenum and proprietary WHISPAIR™ jet to control pressure equalization – feeding backflow in the direction of impeller movement, thereby aiding rotation.

The headplates and rigid, one-piece casing are grey iron, while the drive end cover and gear cover are aluminum. Carburized and ground alloy steel spur timing gears are taper mounted on the shafts, secured with a locknut. Cylindrical roller bearings are used.

Piston rings reduce air leakage through the shaft openings in the headplates, and lip-type oil seals prevent lubricant from entering the air chamber. RAM™ WHISPAIR™ vacuum exhausters incorporate splash oil lubrication at both ends of the units. A lip seal on the drive shaft prevents shaft seal oil leaks.

All frame sizes are designed with detachable rugged steel mounting feet which permit in-field adaptability to either vertical or horizontal installation requirements.

The top shaft is extended for drive on side outlet vacuum exhausters, and the left or right shaft can be extended for drive on bottom outlet vacuum pumps. An inlet spray nozzle and seal water flow meter are supplied for water injection.

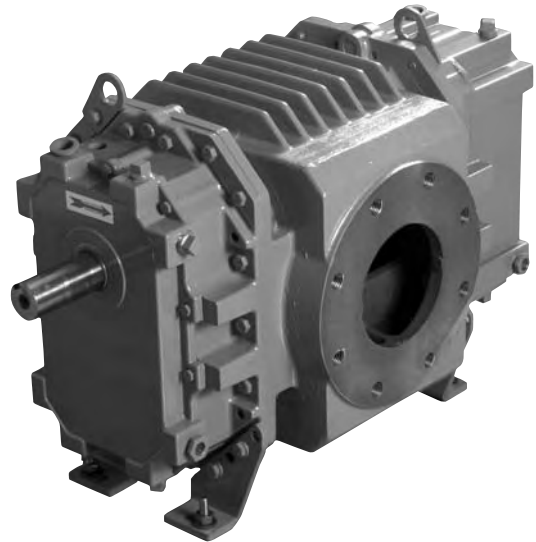

DESIGN AND CONSTRUCTION FEATURES

1. Low noise level, less operating power required
2. Improved volumetric efficiency & reduced operating temperatures
3. Alloy steel timing gears
4. Cylindrical roller bearings
5. Piston ring air seals
6. Lip-type oil and shaft seals
7. Splash oil lubrication
8. Horizontal and vertical configurations available

OPERATING PRINCIPLE

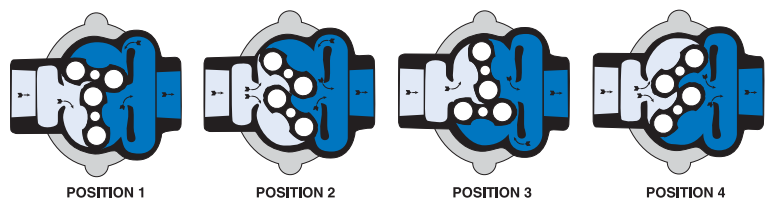

Incoming air is trapped by the impellers. Simultaneously, pressurized air (right) is being discharged. As the lower impeller passes wrap-around flange, Whispair jet equalizes pressure between trapped air and discharge area, aiding impeller movement and reducing power. Impellers move air into the discharge area (right). Backflow is controlled, resulting in reduction of noise relative to conventional blowers.



PERFORMANCE TABLE

FRAME SIZE	SPEED RPM	16" Hg VAC		20" Hg VAC		22" Hg VAC		24" Hg VAC	
		CFM	BHP	CFM	BHP	CFM	BHP	CFM	BHP
406J	1530	154	9.3	118	11.4	86	12.5	31	13.6
	2325	269	15.0	227	18.2	190	19.8	126	21.4
	3200	400	22.4	352	26.7	310	28.8	238	30.9
409J	1530	248	13.6	201	16.8	159	18.4	87	20.0
	2325	412	21.6	353	26.4	300	28.8	209	31.2
	3200	600	31.4	528	37.8	465	46.0	356	44.3
412J	1530	331	17.9	268	22.2	212	24.4	115	26.5
	2325	549	28.1	470	34.6	400	37.8	278	41.0
	3200	797	40.4	703	49.0	619	53.3	474	57.6
418J	1530	497	26.6						
	2325	825	41.4						
	3200	1197	58.5						
616J	1160	695	32.2	614	39.8	538	43.6	420	47.5
	1750	1105	49.9	1003	61.2	908	66.9	760	72.6
	1160	1566	70.9	1445	85.9	1332	93.4	1156	101.0
624J	2400	1044	47.8						
	1750	1658	73.8						
	2400	2350	104.2						

OUTLINE DRAWING & DIMENSIONAL TABLE

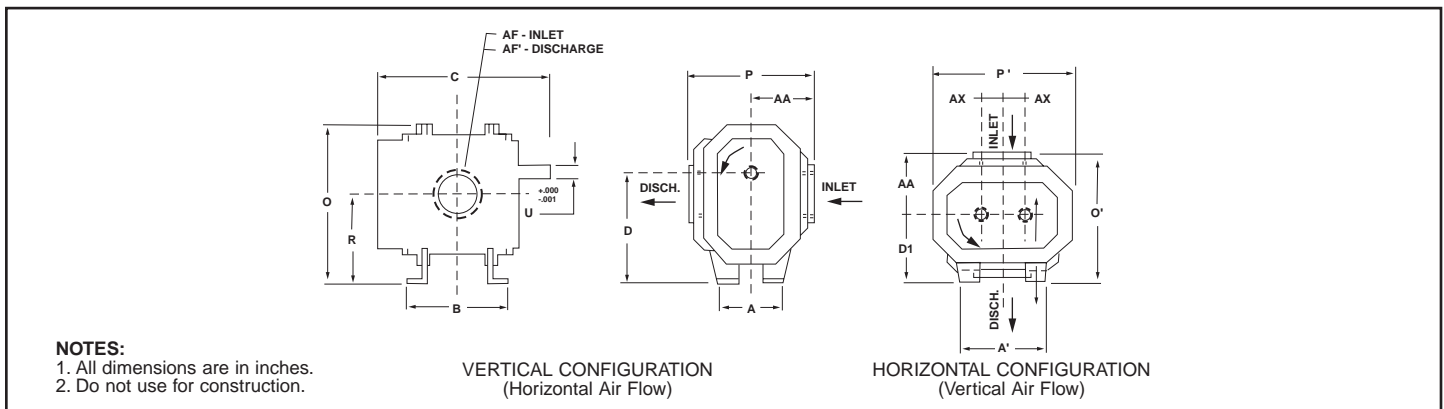

FRAME SIZE	A	A'	B	C	Drive Shaft Location		O	O'	P	P'	R	U	Keyway	AF Inlet Diameter	AF' Discharge Diameter	AA	AX	Approx. Net Wt (lbs)
					D	D1												
406J	8.00	11.00	10.75	20.50	11.25	7.50	16.63	14.75	14.50	15.25	9.00	1.500	.375 x .188	4.0 NPT	4.0 NPT	7.25	2.25	300
409J	8.00	11.00	13.75	23.50	11.25	7.50	16.63	14.75	14.50	15.25	9.00	1.500	.375 x .188	5.0 NPT	5.0 NPT	7.25	2.25	350
412J	8.00	11.00	16.75	26.50	11.25	7.50	16.63	13.50	13.00	15.25	9.00	1.500	.375 x .188	6.0 FLG	5.0 FLG	6.00	2.25	400
418J	8.00	11.00	22.75	32.50	11.25	7.50	16.63	14.50	14.00	15.25	9.00	1.500	.375 x .188	8.0 FLG	6.0 FLG	7.00	2.25	500
616J	10.00	16.00	21.44	32.44	15.00	9.00	22.00	16.50	16.25	20.00	12.00	2.000	.500 x .250	8.0 FLG	6.0 FLG	7.50	3.00	800
624J	10.00	16.00	29.44	40.44	15.00	9.00	22.00	17.75	17.50	20.00	12.00	2.000	.500 x .250	10.0 FLG	8.0 FLG	8.75	3.00	1000

WARRANTY PERIOD

Twelve (12) months from date of original unit start-up or 18 months from date of original shipment, whichever occurs first.

Dresser, Inc.



Roots

Dresser ROOTS
 2135 Hwy 6 South
 Houston, TX 77077
 PH: 281-966-4700
 FX: 281-966-4309
 Toll Free: 1-877-363-ROOT(S)

Dresser ROOTS - Connersville
 900 West Mount Street
 Connersville, IN 47331
 PH: 765-827-9200
 FX: 765-827-9266

Dresser ROOTS - Holmes Operation
 PO Box B7
 Off St. Andrews Rd
 Turnbridge, Huddersfield
 England HD1 6RB
 PH: +44-1484-422222
 FX: +44-1484-422668

S-58F97
 December 2002

©2002 Dresser, Inc.
 ROOTS, RAM and WHISPAIR are trademarks of Dresser, Inc.
 Dresser Design is a registered trademark of Dresser, Inc.

website: www.rootsblower.com • email: ROOTS@dresser.com