

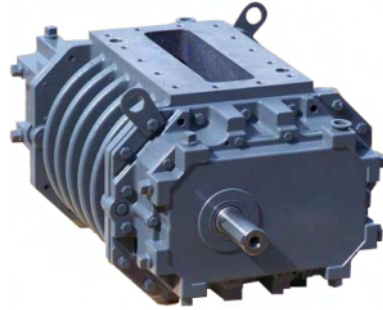

Roots

1000 RAM X

Part Number – call 816-741-0282



RAM X Tri-lobe rotary positive displacement blowers feature ROOTS WHISPAIR™ discharge design which, when combined with tri-lobe impellers, delivers quieter operation than conventional tri-lobe blowers.

- Heavy-duty unit with integral-shaft ductile iron impellers with an involute profile
- Rigid one-piece casing, headplates and end covers are grey iron
- Carburized and ground alloy steel spur timing gears
- Cylindrical roller bearings
- Piston rings reduce air leakage
- Hydrodynamic oil seals prevents oil from entering the air chamber
- Splash oil lubricated gears on drive and gear ends
- Detachable steel mounting feet
- Horizontal and vertical configurations available



816-741-0282



Quick Specs

Flow Range	to 5399 CFM
Max ΔPressure	12 PSI
Max ΔVacuum	16" Hg
Maximum RPM	2670
Minimum RPM	480
Max ΔT	230°F
Option 1 - Rectangular Connection	14" x 32"
Option 2 - Flange Connection	14" Flange
Shaft Dia.	70mm/2.75"
Min Sheave Dia.	13.2"
Drive End Lubrication	Oil
Gear End Lubrication	Oil
Oil Sump Horiz Config	~376 oz
Oil Sump Vert Config	~224 oz
Bare Unit Weight	2500 lbs (1)
Bare Unit Weight w/Adapters & Feet	2870 lbs (2)
Shipping Weight on Skid	~2550 lbs (1)
Shipping Weight on Skid	~2920 lbs (2)
Recommended to Ship Via	Truck
Container	Wood Skid
Skid Size (L x W x H)	54" x 48" x 36"



816-741-0282

RAM X™ Blowers Parts List - Models 800 and 1000

Item Number	Part Name	Quantity
1	Headplate	2
3	Gearbox	1
4	Timing Gears	2
5	End Cover	1
7	Gasket – Gearbox/Cover	2
10	Shims	Lot
11	Cylinder	1
12	Impeller & Shaft Drive	1
13	Impeller & Shaft Driven	1
14	Bearing Roller	4
16	Pin, Dowel (Pull Out)	4
17	Pin, Dowel	2
19	Key Square	1
21	Breather	2
22	Plug, Pipe	12
23	Screw, Cap Hex Hd.	*
27/27A	Seal, Hydrodynamic	4
28	Piston, Ring-Seal	4
29	Washer, Wavy Spring	2
31	Gear Nut	2
32	Scr, Cap Hex Hd.	16
33	Seal, Hydrodynamic	1
34	Brg. Clamp Plate - D. E.	2
35	Lock Washer - Spring	16
37	Sight Plug - Oil Level	2
38	Sleeve, Shaft	4
40	Slinger - D.E. (Top Drive)	1
46	Slinger - G.E.	1
54	Brg Clamp Plate - G. E.	2
55	Screw, Cap Butt. HD.	2
56	Washer, Plain	2
60	Screw, Cap Butt. HD.	1
64	Pin, Spring	1
65	Coupling Pipe	2
66	Close Nipple	2
73	Blower Foot - RH (optional)	2
74	Blower Foot - LH (optional)	2
78	Capscrews	6
88	Anti Rotation Ball	4
210	Inlet/Discharge Gasket	2
85.1	Plug, Pipe	2
87	Scr, Cap BH	2
88	Anti Rotation Ball	4
90	BSHG-RDCG	2
91	Washer, Plain Flat	2
92	Washer, Plain Flat	2
93	Washer	2
94	Oil Leader	2
95	Cap Screw	4
210	Inlet/Discharge Gasket	2

*Quantity varies by blower.

FYdUjf ' ? Jhg'

Repair kits are bundled with the parts you need to complete a standard repair. It is more cost effective to buy a repair kit than to purchase individual parts. However, if you need parts not listed in the kit, it is recommended that you call Pathfinder Systems for parts pricing.

Hcdž @Zžcf'F][\ h8fj] Y'G UZif6cHca 'G UZicfXYf'D#B' - '\$+%&F?Ł
D#B' - '\$+%&F? ? JhZcf', \$\$!%\$\$\$'F5AL'

QTY	Part Name	Part Number
*	Sleeve Seal Install Tool Drive	13365029
*	Sleeve Seal Install Tool Inboard	13728004
7	Gasket Headplate	57178021
10	Shim Set	64095020
14	Antirotaion Bearing	92870020
27	Hydrodynamic Seal, (PTFE) CW	13309023
27A	Hydrodynamic Seal, (PTFE) CCW	13309024
28	Piston, Ring Seal	12283005
29	Washer, Spring, Wavy	10135019
31	Hex Cap Screw 7/8	12467017
33	Hydrodynamic Seal, (PTFE)	13440004
37	Sight Plug Oil Level 3/4	12066001
38	Sleeve, GE & OGE 800 RCS-J	57161020
40	Slinger DE	67884012
46	Slinger GE	66996012
48	Washer, Plain Flat	10181013
49	Screw Cap 3/8-16	10219003
62	Screw Cap Hex Head 7/8-9	10342001
69	Washer, HDN	12750003
74	Pin, Spring 3/16x1	10068054
88	Anti-rotational Ball 1/4	10409010

*A special tool is required to install the uni-directional seal.



816-741-0282

Table 2 - Recommended Oil Grades

Ambient* Temperature °F (°C)	ISO Viscosity No.
Above 90° (32°)	320
32° to 90° (0° to 32°)	220
0° to 32° (-18° to 0°)	150
Below 0° (-18°)	100

*Ambient temperature is defined as the temperature of the space in which the blower and drive are located.

Use a good grade of **industrial type** non-detergent, rust inhibiting, anti-foaming oil and of correct viscosity per Table 2. Roots synthetic oil (Roots P/N 813-106-) is **specified and recommended**. Roots does not recommend automotive type lubricants, as they are not formulated with the properties mentioned above.

Due to sludge build-up and seal leakage problems, Roots recommendation is DO NOT USE Mobil SHC synthetic oils in ROOTS blowers.

Table 3 - RAM X™ Approximate Oil Sump Capacities

Model Number/ Drive Shaft Location	Gearbox		Drive End	
	Fluid Ounces	Liters	Fluid Ounces	Liters
155,225,280 (left or right)	36	1.06	19	0.56
155, 225, 280 (top or bottom)	18	0.52	9	0.27
400, 500 (left or right)	95	2.81	50	1.48
400, 500 (top or bottom)	55	1.63	28	0.83
600, 770 (left or right)	155	4.59	70	2.07
600, 770 (top or bottom)	80	2.37	40	1.18
800, 1000 (left or right)	256	7.6	120	3.5
800, 1000 (top or bottom)	144	4.3	80	2.37

These capacities are provided to assist stocking the correct amount of oil. Exact sump capacity may differ slightly. See "Lubrication" section for proper filling instructions.

ROOTS® Synthetic Oil: ISO-VG-320 Grade	
	Part Number
Quart	13106004
Gallon	13106005
Case (12 qts)	13106007
ROOTS® Synthetic Oil: ISO-VG-220 Grade	
	Part Number
Quart	13106001
Gallon	13106002
Case (12 qts)	13106008
ROOTS® Synthetic Oil: ISO-VG-150 Grade	
	Part Number
Quart	13106020
Gallon	13106021
Case (12 qts)	13106023
5 Gallon Pail	13106022
55 Gallon Drum	13106025
ROOTS® Synthetic Oil: ISO-VG-100 Grade	
	Part Number
Quart	13106011
Gallon	13106012
Case (12 qts)	13106014
5 Gallon Pail	13106013
55 Gallon Drum	13106016

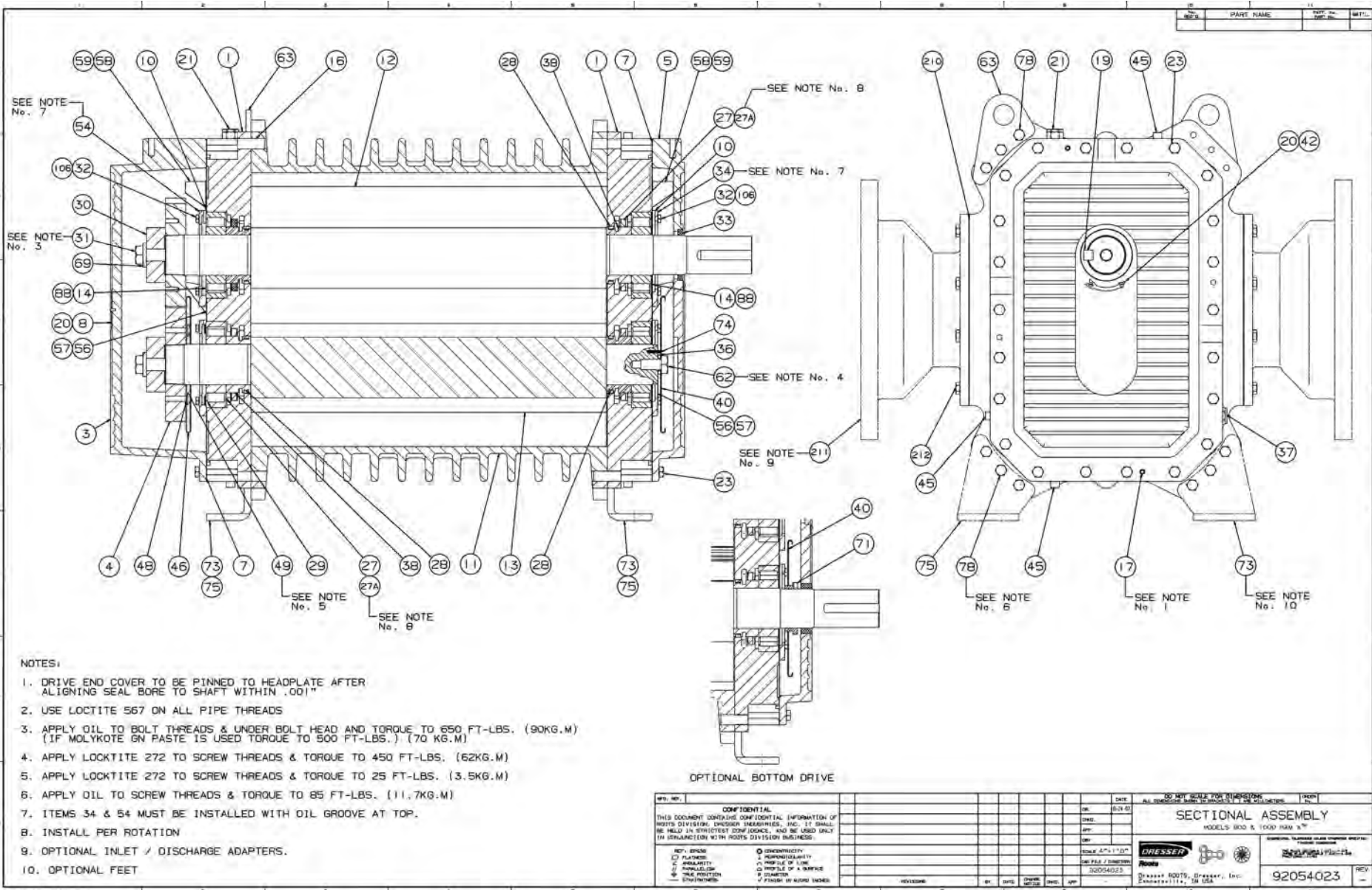

Assembly of RAM X™ Tri-Lobe Blowers Models 800 & 1000

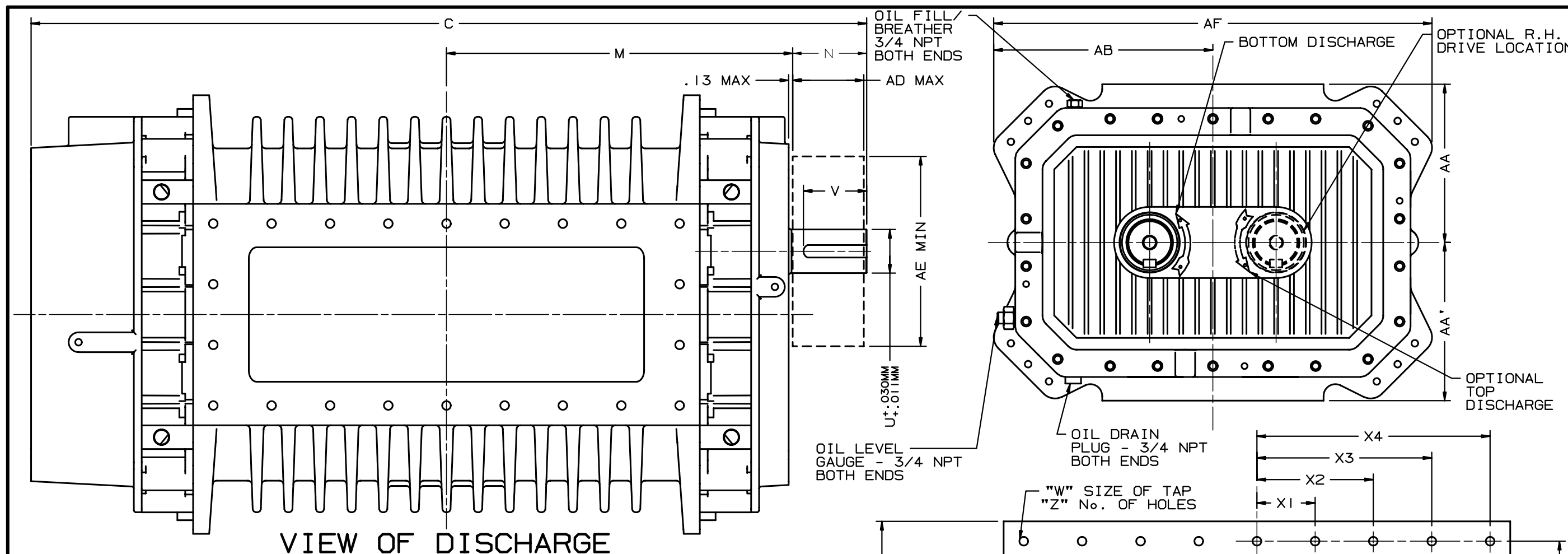

INLET & DISCHARGE FLANGES TO MATE FLUSH & SQUARE WITH FLAT FACE FLANGE ONLY. USE FULL FACE GASKETS.

V-BELT DRIVEN UNITS: MOTOR TO BE LOCATED ON INLET SIDE OF HORIZONTAL FLOW UNITS & ON DRIVE SHAFT SIDE OF VERTICAL FLOW UNITS.

AD - MAXIMUM SHEAVE WIDTH (SEE OVERHUNG LOAD LIMIT K-24102)

AE - MINIMUM SHEAVE DIAMETER (SEE OVERHUNG LOAD LIMIT K-24102)

ALL DIMENSIONS IN INCHES UNLESS OTHERWISE SPECIFIED METRIC DIMENSIONAL #90776021

DISCH. LOCATION	DRIVE LOCATION	
	LH	RH
TOP	CW	CCW
BOTTOM	CCW	CW

UNIT IS BUILT TO CUSTOMERS SPECIFIED ORIENTATION

MODEL	C	M	N	U MM	V MM	KEYWAY MM	INLET AA	DISCH AA'	AB	AD	AE	AF	AG	AH	AJ	AK	JAK	APPROX WEIGHT
800	46.98	18.70	4.94	70.0	102.0	20.0X8.0	10.00	10.00	13.86	7.19	13.20	27.72	20.00	8.50	14.00	26.00	2000 LBS	
1000	52.98	21.71	"	"	"	20.0X8.0	"	"	"	"	"	25.00	"	"	"	32.00	2500 LBS	

MODEL	X1	X2	X3	X4	Y1	Y2	W	Z
800	3.91	7.82	-	11.75	1.92	5.75	M16x2	18
1000	3.68	7.36	11.06	14.75	1.92	5.75	M16x2	22

CERTIFIED CORRECT FOR
CUSTOMER ORDER No. _____
ROOTS ORDER No. _____
DATE _____

REVISIONS	BY	CHANGE NOTICE	CHKD.	APP.	V-BELT DRIVE DATA
					BELTS
					DRIVE SHEAVE
					DRIVEN SHEAVE
					CENTER DISTANCE

RAM X™
TRI-LOBE BLOWERS
MODELS 800 & 1000



Dresser ROOTS, Dresser, Inc.
Connersville, IN USA

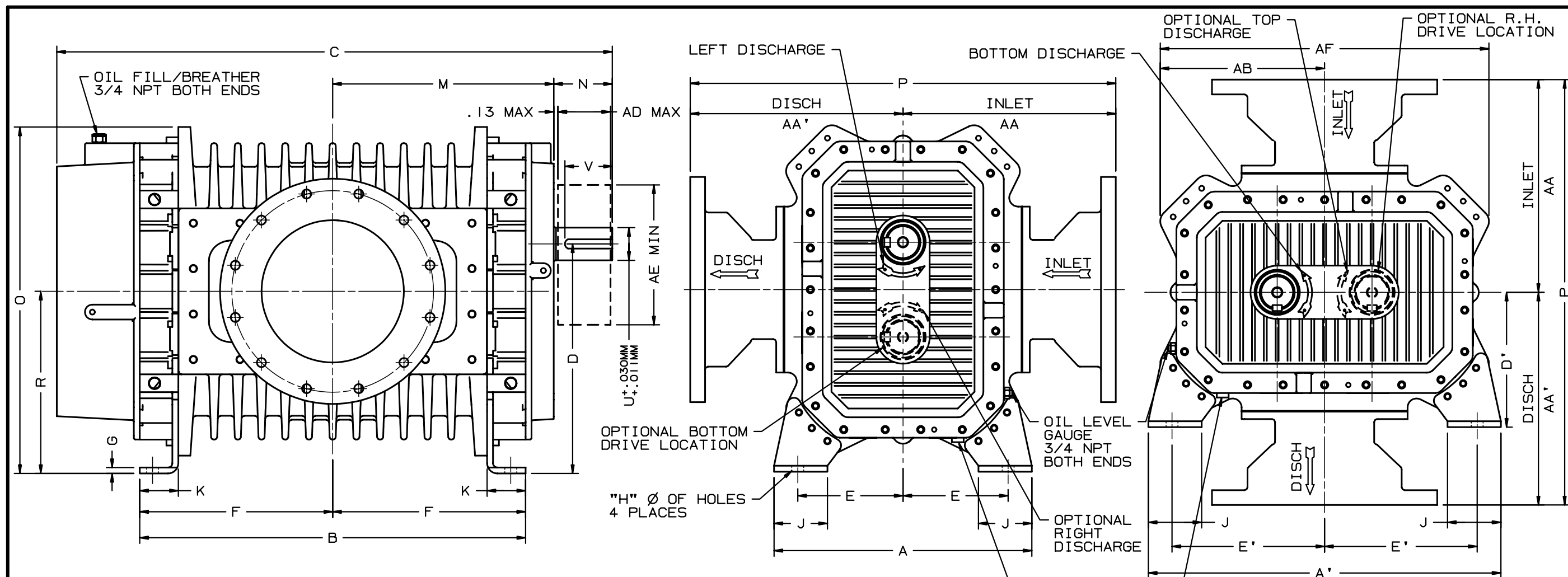

INLET & DISCHARGE FLANGES TO MATE FLUSH & SQUARE WITH FLAT FACE FLANGE ONLY. USE FULL FACE GASKETS.

V-BELT DRIVEN UNITS: MOTOR TO BE LOCATED ON INLET SIDE OF BLOWER.

AD - MAXIMUM SHEAVE WIDTH (SEE OVERHUNG LOAD LIMIT K-24102)

AE - MINIMUM SHEAVE DIAMETER (SEE OVERHUNG LOAD LIMIT K-24102)

ALL DIMENSIONS IN INCHES UNLESS OTHERWISE SPECIFIED METRIC DIMENSIONAL #92520021

ANSI FLANGE DIMENSIONS						
	FA	FB	FC	FD	FE	FG
12 FLG	12.00	17.00	19.00	12	.88-9	1.25
14 FLG	14.00	18.75	21.00	12	.88-9	1.50

FA - FLANGE OPENING
 FB - FLANGE BOLT CIRCLE
 FC - FLANGE O.D.
 FD - No. TAPPED HOLES
 FE - SIZE OF TAPPED HOLES
 FG - DEPTH OF TAP

DRIVE LOCATION		
DISCH. LOCATION	DRIVE LOCATION	
	LH	RH
TOP	CW	CCW
BOTTOM	CCW	CW

UNIT IS BUILT TO CUSTOMERS SPECIFIED ORIENTATION

MODEL	A	A'	B	C	D	D'	E	E'	F	G	H	J	K	M	N	O	P	R	U	V	KEYWAY	INLET	DISCH	AB	AD	AE	AF	INLET/DISCH FLANGE SIZE	APPROX WEIGHT
																			MM	MM	MM	AA	AA'						
800	21.74	29.73	32.54	46.98	9.36	1.37	8.87	12.87	16.27	0.5	1.00	4.50	3.25	18.70	4.94	29.23	35.89	15.37	70.00	102.0	20.0X8.0	17.94	17.94	13.86	7.19	13.20	27.72	12"	2300 LBS
1000	"	"	38.55	52.98	"	"	"	"	19.27	"	"	"	"	21.71	"	"	36.38	"	"	"	20.0X8.0	18.19	18.19	"	"	"	"	14"	2870 LBS

CERTIFIED CORRECT FOR		V-BELT DRIVE DATA		RAM X™ TRILOBE BLOWERS MODELS 800 & 1000	Dresser ROOTS, Dresser, Inc. Connersville, IN USA	92519021	REV.
CUSTOMER ORDER No. _____		BELTS					
ROOTS ORDER No. _____		DRIVE SHEAVE					
DATE _____		DRIVEN SHEAVE					
REVISIONS	BY	CHANGE NOTICE	CHKD.	APP.	DR	CHKD	APP

ROOTS

Blowers Compressors Exhausters

RAM X™

ROOTS™ RAM X™ Tri-Lobe Rotary Positive Displacement Blowers

Models 155, 225, 280, 400, 500, 600, 770, 800, 1000

The ROOTS™ RAM X™ tri-lobe positive displacement blower has been designed to incorporate the latest technology for reduced noise and vibration and minimal downstream pulse. This series is based upon the field operation success of ROOTS RAM™ blower series and features state-of-the-art engineering based on tri-lobe principles originally designed by Roots.

BLOWER DESCRIPTION

RAM X tri-lobe rotary blowers are heavy-duty units with high strength integral-shaft ductile iron impellers designed for maximum efficiency. The blowers feature ROOTS WHISPAIR™ discharge design which, when combined with tri-lobe impellers, delivers quieter operation than conventional tri-lobe blowers.

The headplates and rigid, one-piece cylinder are cast iron, while the drive-end and gear covers are aluminum (cast iron for models 600-1000). Carburized and ground alloy steel spur timing gears are taper mounted on the shafts and are secured with a locknut (bolt for models 800-1000). Cylindrical roller bearings are used to accept side loads from v-belt drives.

Piston rings reduce air leakage through the shaft openings in the headplates and hydrodynamic oil seals prevent lubricant from entering the air chamber. RAM X blowers incorporate thrust control, with splash oil lubrication at both ends of the blower.

All model sizes are designed with detachable rugged steel mounting feet which permit in-field adaptability to either vertical or horizontal installation requirements.

The top shaft is adaptable for drive on side outlet blow-

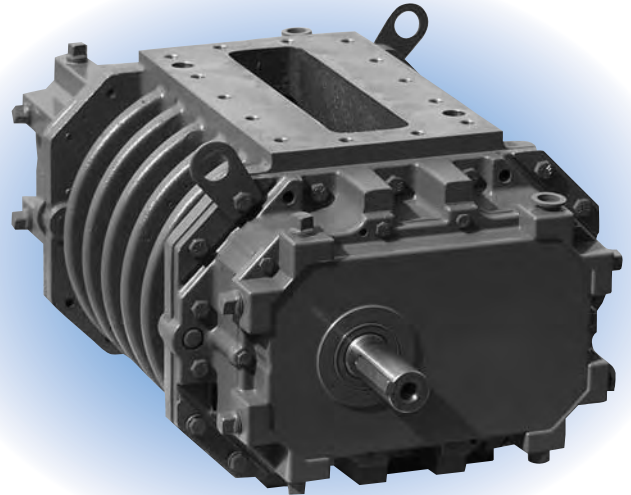

ers, and either shaft can be extended for drive on top or bottom outlet blowers.

DESIGN FEATURES AND BENEFITS

- Tri-lobe impellers for less vibration and minimal downstream pulse
- WHISPAIR discharge design combined with tri-lobe impellers for quieter operation than conventional tri-lobe blowers
- Carburized and ground alloy steel timing gears for long life and consistent performance
- Cylindrical roller bearings for longer bearing life
- Piston ring seals for less air leakage
- Splash lubrication from oil sumps with sight glasses on each end for easy maintenance
- Detachable feet and drive shaft extension to adapt to horizontal or vertical configuration

WARRANTY PERIOD

Models 155-500: Twenty-four (24) months from date of original unit start-up or 30 months from date of original shipment, whichever occurs first.

Models 600-1000: Twelve (12) months from date of original unit start-up or 18 months from date of original shipment, whichever occurs first.



OUTLINE DRAWING & DIMENSIONS

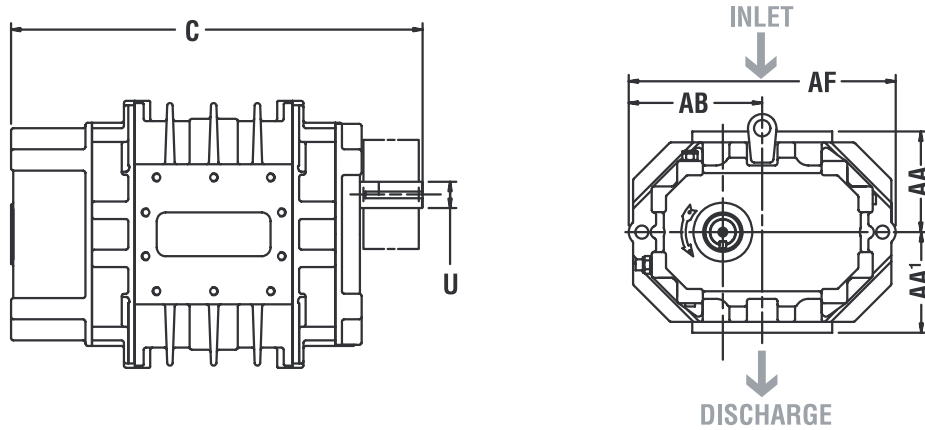

Dimensions are in inches (except U and Keyway are mm), weight is in pounds.

Model	C	U	Keyway	AA	AA'	AB	AF	Approx. Wt.
155	23.50	35	10 x 5.0	5.75	5.75	7.63	15.25	300
225	27.50	35	10 x 5.0	5.75	5.75	7.63	15.25	360
280	30.75	35	10 x 5.0	5.75	5.75	7.63	15.25	420
400	33.56	50	14.0 x 5.5	7.25	7.25	10.0	20.0	730
500	37.73	50	14.0 x 5.5	7.25	7.25	10.0	20.0	850
600	41.17	60	18.0 x 7.0	8.63	8.63	11.63	23.25	1325
770	46.92	60	18.0 x 7.0	8.63	8.63	11.63	23.25	1540
800	46.98	70	20.0 x 8.0	10.0	10.0	13.86	27.72	2000
1000	52.98	70	20.0 x 8.0	10.0	10.0	13.86	27.72	2500

PERFORMANCE TABLE

Model	Speed RPM	4 PSI		6 PSI		8 PSI		10 PSI		12 PSI		15 PSI		Max. Vacuum		
		CFM	BHP	CFM	BHP	CFM	BHP	CFM	BHP	CFM	BHP	CFM	BHP	"HG	CFM	BHP
155	2000	317	7.2	301	10.6	288	13.9	276	17.3	266	20.7	251	25.7	15	253	12.6
	3560	618	14.8	602	20.8	589	26.8	577	32.8	567	38.8	553	47.8	16	545	24.7
	4750	847	22.8	832	30.8	818	38.8	807	46.7	796	54.7	782	66.7	16	774	34.4
225	2000	459	10.3	436	15.2	417	20.1	400	25	385	29.8	364	37.2	15	366	18.2
	3560	895	20.9	872	29.5	853	38.2	836	46.9	821	55.6	800	68.6	16	789	35.6
	4750	1227	31.5	1205	43.1	1186	54.7	1169	66.3	1154	77.9	1133	95.2	16	1122	49.2
280	2000	573	13.01	545	19.1	521	25.2	500	31.3	481	37.4			15	458	22.7
	3560	1118	26.3	1090	37.1	1066	48	1045	58.8	1026	69.7			16	986	44.6
	4750	1534	39.9	1506	54.5	1482	68.9	1461	83.4	1442	97.8			16	1402	61.7
400	1500	801	18.2	758	26.8	721	35.5	689	44.2	660	52.8			14	648	30.1
	2500	1463	33	1420	47.04	1383	61.8	1351	76.3	1322	90.7	1283	112	16	1261	58.3
	3560	2165	53.1	2122	73.6	2085	94.2	2053	114.72	2024	135.3	1985	166.1	16	1963	85.9
500	1500	995	23	941	33.8	896	44.5	856	55.3	820	66			14	805	37.6
	2500	1817	43.1	1763	61	1718	78.9	1678	96.8	1642	114.8			16	1566	73.4
	3560	2688	72.1	2634	97.6	2589	123.1	2549	148.6	2513	174.1			16	2437	109.6
600	1400	1360	31.3	1294	45.7	1238	60.1	1189	74.6	1144	89			14	1127	50.7
	2200	2307	54.8	2240	77.4	2184	100.1	2135	122.8	2090	145.5	2030	179.6	16	1998	93.1
	3050	3312	88	3246	119.4	3190	150.9	3141	182.3	3096	213.8	3035	261	16	3003	134.8
770	1400	1705	39.1	1622	57.2	1552	75.3	1490	93.4	1434	111.5			14	1413	63.5
	2200	2892	68.1	2809	96.6	2738	125	2676	153.5	2620	181.9			16	2504	116.5
	3050	4152	108.9	4069	148.4	3999	187.8	3937	227.3	3881	266.7			16	3765	168.3
800	1300	1898	43.3	1808	63.3	1732	83.3	1666	103.4	1605	123.4			14	1582	70.3
	1900	2958	68.6	2868	97.9	2793	127.2	2726	156.5	2666	185.7	2584	229.6	16	2541	119.2
	2670	4319	110.3	4229	151.5	4153	192.6	4086	233.7	4026	274.9	3945	336.6	16	3901	174
1000	1300	2372	54.0	2260	79	2166	104.1	2082	129.1	2007	154.1			14	1978	87.8
	1900	3698	85.4	3586	122	3491	158.6	3408	195.2	3332	231.8			16	3176	148.9
	2670	5399	136.9	5287	188.3	5192	239.8	5109	291.2	5033	342.6			16	4877	217.1

Notes: 1. Pressure ratings are based on inlet at standard pressure of 14.7 psia, standard temperature of 68° F and specific gravity of 1.0.
2. Vacuum ratings are based on inlet air at standard temperature of 68° F, discharge of 30" Hga and specific gravity of 1.0.



Roots

www.rootsblower.com Visit "Contact Us" page for your nearest location
Houston, Texas Headquarters • U.S. Toll Free Phone: 1-877-363-ROOT(S) (7668) • Direct Phone: 832-590-2600
Connersville, Indiana Operations • U.S. Toll Free Phone: 1-877-442-7910 • Direct Phone: 765-827-9285
United Kingdom Operations • Phone: +44 (0) 1695 52600
USA/Canada Sales • Phone: 773-444-3360
Houston, Texas Factory Service • Phone: 713-896-4810
Mexico City Sales and Factory Service • Phone: +52 55 5889 5811
Dubai Sales and Factory Service • Phone: +971 4-8830831
Malaysia Sales • Phone: +60 3 2163 0480
China Sales • Phone: +86 10 8486 2440
Shanghai Factory Service • Phone: +86 21 5858 7638

S-RAMX-EAX2 rev.0907

©2007 Dresser, Inc. all rights reserved. • Printed in the U.S.A. • All information subject to change without notice. • ROOTS, RAM, RAM X, and WHISPAIR are trademarks of Dresser, Inc. EASYAIR is a registered trademark of Dresser, Inc.