



Roots

42 URAI-DSL

Part Number – T30352020



- Detachable steel mounting feet
- Rigid one-piece cast iron casing
- Connections in standard pipe sizes
- Straight, precision machined two-lobe impellers
- Splash oil lubricated gear and drive ends
- Carburized and ground alloy steel spur timing gears
- Anti-Friction gears
- Ground steel shafts
- Center Timed for rotation in either direction

Also Available in:

- URAI
- URAI-G (Gas)
- URAI-Metric

Equivalent to:

Sutorbilt Model 4HP
Tuthill Model 4002



816-741-0282



Quick Specs

Flow Range	to 330 CFM
Max ΔPressure	15 PSI
Max ΔVacuum	16" Hg
Maximum RPM	3600
Minimum RPM	848
Max ΔT	240°F
Connection Size	1.5" FPT
Shaft Dia.	0.875"
Min Sheave Dia.	5"
Drive End Lubrication	Oil
Gear End Lubrication	Oil
Oil Sump Gear End Horiz Config	~14.5 oz
Oil Sump Gear End Vert Config	~12.7 oz
Oil Sump Drive End Horiz Config	~10.9 oz
Oil Sump Drive End Vert Config	~5.5 oz
Bare Unit Weight	81 lbs
Shipping Weight	86 lbs
Shipping Container	Box
Box Size (L x W x H)	17" x 16" x 12"
Can Ship via	UPS Insured



816-741-0282

Universal RAI-DSL Series Blowers Parts List 3-1/2" – 5" Gear Diameter

(Refer to drawing #T30356023)

Item #	Part Name	Qty.
1	Headplate Gear End	1
2	Headplate Drive End	1
3	Gearbox	1
4	Timing Gears	2
7	Gasket, Gear Box, DE Cover	1
11	Cylinder	1
12	Impeller & Shaft Drive	1
13	Impeller & Shaft Driven	1
14	Bearing, Ball	3
15	Bearing, Roller	1
16	Pin, Dowel	4
17	Gear Nut	2
19	Key	1
21	Plug, Pipe	3
23	Screw Hex	6
25	Breather (Plug Vent)	1
26	Screw, Hex	*
27	Seal, Lip Bearing	4
31	Screw, Hex, Nylock	4
32	Screw, Hex	6
33	Seal Lip-Drive	1
34	Clamp Plate	2
35	Foot	2
39	Washer Mounting	4
40	Screw Socket	2
42	Screw Hex	2
48	DE Oil Slinger Set Screw	4
50	Drive End Cover	1
52	Drive End Oil Slinger	2
53	Oil Sight Glass	2

*Quantities vary by blower.

320

Table 2 - Recommended Oil Grades

Ambient* Temperature °F (°C)	Viscosity No.
Above 90° (32°)	space in which the
32° to 90° (0° to 32°)	
0° to 32° (-18° to 0°)	
Below 0° (-18°)	

*Ambient temperature is defined as the temperature of the blower and drive are located.

Due to sludge build-up and seal leakage problems, Roots recommendation is DO NOT USE Mobil SHC synthetic oils in ROOTS blowers.

Repair Kits

Repair kits are bundled with the parts you need to complete a standard repair. It is more cost effective to buy a repair kit than to purchase individual parts.

However, if you need parts not listed in the kit, it is recommended that you call Pathfinder Systems for parts pricing.

P/N 651080RK Kit without Gears for 42, 45, 47 URAI, URAI-DSL, URAI-J, URAI-J-DSL, URAI-Metric, URAI-DSL-Metric

Item	Qty	4" Kit Description	P/N
5	1	PLUG,OPENING for 2.4411	12957004
7	2	GSKT,GRBX 4 URAI TS9003	62757021
14	3	BRG,BALL	10987040
15	1	BRG,ROLLER	10222036
17	2	NUT,HEX ESNA 3/4-16	10319009
27	4	SEAL,LIP(VITON) 1 SFT	10005158
31	4	SCR,CAP HEXH NYL 1/4-20X	11540003
33	1	SEAL,LIP for GREASE LUBE	12091010
33A	1	SEAL,LIP for DSL	T20082002

P/N 651070RK Kit with Gears for 42, 45, 47 URAI, URAI-DSL, URAI-J, URAI-J-DSL, URAI-Metric, URAI-DSL-Metric

Item	Qty	4" Kit Description	P/N
4	1	GEAR,ASSY 4 URAI T/B	63865021
5	1	PLUG,OPENING for 2.4411	12957004
7	2	GSKT,GRBX 4 URAI TS9003	62757021
14	3	BRG,BALL	10987040
15	1	BRG,ROLLER	10222036
17	2	NUT,HEX ESNA 3/4-16	10319009
27	4	SEAL,LIP(VITON) 1 SFT	10005158
31	4	SCR,CAP HEXH NYL 1/4-20X	11540003
33	1	SEAL,LIP for GREASE LUBE	12091010
33A	1	SEAL,LIP for DSL	T20082002

ROOTS® Synthetic Oil: ISO-VG-320 Grade

	Part Number
Quart	13106004
Gallon	13106005
Case (12 qts)	13106007

ROOTS® Synthetic Oil: ISO-VG-220 Grade

	Part Number
Quart	13106001
Gallon	13106002
Case (12 qts)	13106008

ROOTS® Synthetic Oil: ISO-VG-150 Grade

	Part Number
Quart	13106020
Gallon	13106021
Case (12 qts)	13106023
5 Gallon Pail	13106022
55 Gallon Drum	13106025

ROOTS® Synthetic Oil: ISO-VG-100 Grade

	Part Number
Quart	13106011
Gallon	13106012
Case (12 qts)	13106014
5 Gallon Pail	13106013
55 Gallon Drum	13106016

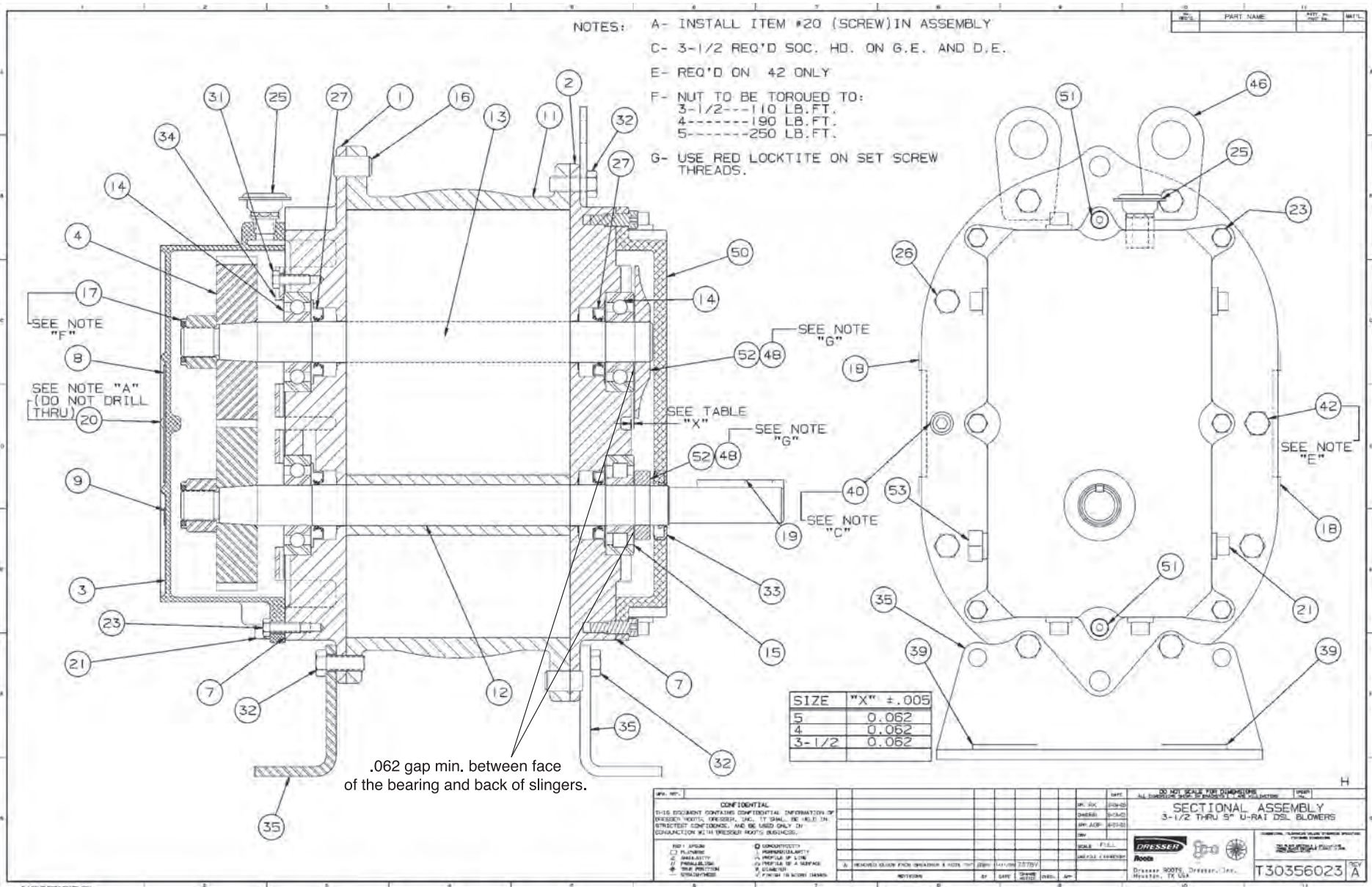

Assembly of UNIVERSAL RAI Series - DSL with Splash Lubricated Drive End 3-5" Gear Diameter

FRAME	APPROX. OIL CAPACITY			
	GEAR END SUMP		DRIVE END SUMP	
	VERTICAL	HORIZONTAL	VERTICAL	HORIZONTAL
3-1/2	8.5 FL. OZ.	16.0 FL. OZ.	4.0 FL. OZ.	6.5 FL. OZ.
4	12.7 FL. OZ.	22.8 FL. OZ.	5.5 FL. OZ.	10.8 FL. OZ.
5	16.0 FL. OZ.	27.6 FL. OZ.	7.5 FL. OZ.	14.8 FL. OZ.

No. RED'D.	PART NAME	PATT. No. PART No.	MAT'L.

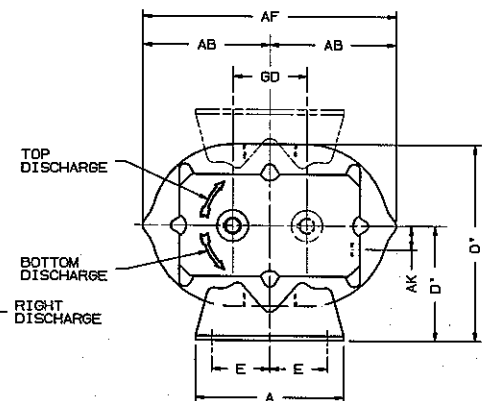
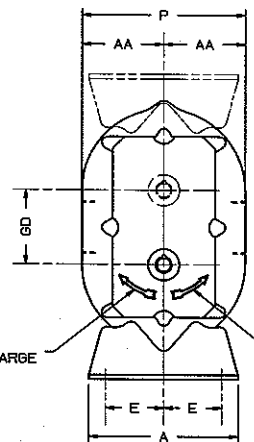
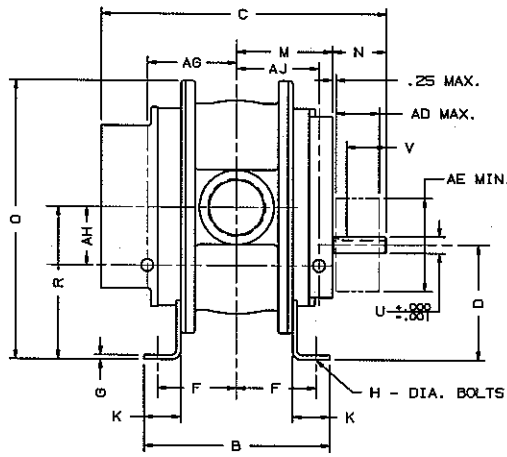

W - INLET & DISCHARGE
AD - SHEAVE WIDTH
AE - SHEAVE DIAMETER

ALL DIMENSIONS IN INCHES

UNIVERSAL[®] RAI DSL BLOWER

FRAME SIZE	GD	A	B	C	D	D'	E MIN.	E MAX.	F MIN.	F MAX.	G	H	K	M	N	O	O'	P	R	U	KEYWAY	W NPT.	V	AA	AB	AD	AE	AF	AG	AH	AJ	AK	APPROX. WT. LBS	
32	3.50	7.25	6.75	11.25	5.00	5.00	2.50	2.98	2.56	2.81	.25	.44	1.75	3.53	2.28	12.81	6.88	7.75	6.75	.750	188x.094	1-1/4"	1.63	3.88	6.06	1.91	5.00	12.13	3.25	2.75	2.88	1.13	72	
33	"	"	7.63	12.13	"	"	"	"	3.00	3.25	"	"	"	3.97	"	"	"	"	"	"	2"	2"	2.13	"	"	"	"	"	"	"	"	3.32	77	
36	"	"	10.00	14.63	"	"	"	"	4.18	4.44	"	"	"	5.18	2.40	"	"	"	"	"	2-1/2"	1.75	"	"	"	"	"	"	"	"	"	4.61	105	
42	4.00	8.00	7.25	13.00	6.25	6.25	3.00	3.13	2.50	3.13	.31	.44	2.00	3.78	3.08	15.06	10.63	8.75	8.25	.875	188x.094	1-1/2"	2.31	4.38	6.81	2.31	5.00	13.63	3.57	3.00	3.00	1.21	92	
45	"	"	10.00	15.50	"	"	"	"	3.56	4.25	"	"	"	5.18	2.84	"	"	"	"	"	2-1/2"	2.13	"	"	"	"	"	"	"	"	"	4.94	4.38	113
47	"	"	11.75	17.63	"	"	"	"	4.63	5.38	"	"	"	6.03	3.22	"	10.50	9.50	"	"	3"	2.50	4.25	"	"	"	"	"	"	"	5.82	5.25	132	
53	5.00	10.50	8.38	15.38	6.25	6.75	3.50	3.50	3.18	3.68	.25	.50	1.88	4.53	3.68	17.38	11.88	10.28	8.75	1.125	25 x 125	2-1/2"	2.75	5.13	8.63	3.06	6.00	17.25	4.32	4.13	3.84	1.63	148	
56	"	"	11.00	17.50	"	"	"	"	4.25	5.00	"	"	"	5.84	3.34	"	12.25	11.00	"	"	4"	2.50	5.50	"	"	"	"	"	"	"	5.45	5.15	175	
59	"	"	14.00	21.00	"	"	"	"	6.00	6.50	"	"	"	7.34	3.84	"	"	"	"	"	4"	3.00	"	"	"	"	"	"	"	"	6.95	6.65	208	

WFO. REF.											DATE	DO NOT SCALE FOR DIMENSIONS ALL DIMENSIONS SHOWN IN BRACKETS () ARE MILLIMETERS										ORDER No.													
CONFIDENTIAL															DR. RK	06/06/03	ASSY DIM 32-59 URAI DSL VH																		
THIS DOCUMENT CONTAINS CONFIDENTIAL INFORMATION OF DRESSER ROOTS, DRESSER, INC. IT SHALL BE HELD IN STRICTEST CONFIDENCE, AND BE USED ONLY IN CONJUNCTION WITH DRESSER ROOTS BUSINESS.															CHND. RK	06/06/03																			
REF: EP88															APP. ASP	08/18/03																			
<ul style="list-style-type: none"> □ FLATNESS ∠ ANGULARITY ∥ PARALLELISM ⊕ TRUE POSITION — STRAIGHTNESS ⊙ CONCENTRICITY ⊥ PERPENDICULARITY — PROFILE OF A LINE — PROFILE OF A SURFACE ⌀ DIAMETER √ FINISH IN MICRO INCHES PARTS/XXAD 62735a21 															QW																				
A ADDED SIGHT GLASS LOCATING DIMENSIONS															RDG	2/2/04	T240	ASP	ASP	<p>DRESSER ROOTS, DRESSER, Inc. HOUSTON, TX USA</p>															DIMENSIONAL TOLERANCES UNLESS OTHERWISE SPECIFIED FINISHED DIMENSIONS TO PLACE DIMENSIONS IN PARENTHESES () ARE MILLIMETERS T30355021
REVISIONS															BY	DATE	CHANGE NOTICE	CHND.	APP	REV A															

ROOTS™ UNIVERSAL RAI DSL® DUAL SPLASH LUBRICATED ROTARY POSITIVE BLOWERS

Frames 32 thru 615

BASIC BLOWER DESCRIPTION

Universal RAI DSL® (Dual Splash Lubricated) blowers are heavy-duty rotary blowers designed with detachable, rugged steel mounting feet that permit easy, in-field adaptability to vertical or horizontal installation requirements. Because of the detachable mounting feet, these units can be easily adapted to any of four drive shaft positions: right, left, bottom, or top. The compact, sturdy design is engineered for continuous service when operated in accordance with speed and pressure ratings.

This model consists of a cast iron casing, carburized and ground alloy steel spur timing gears secured to steel shafts with a taper mounting and locknut, and cast iron involute impellers. Oversized antifriction bearings are used, with a cylindrical roller bearing at the drive shaft to withstand V-belt pull.

The Universal RAI DSL® blower features splash oil lubrication on both the gear end AND drive end. ROOTS' exclusive "figure-eight" gearbox design improves oil distribution to maximize gear and bearing life. Sight glasses (3/8") are provided for accurate

OUTLINE DRAWING & DIMENSIONAL TABLE

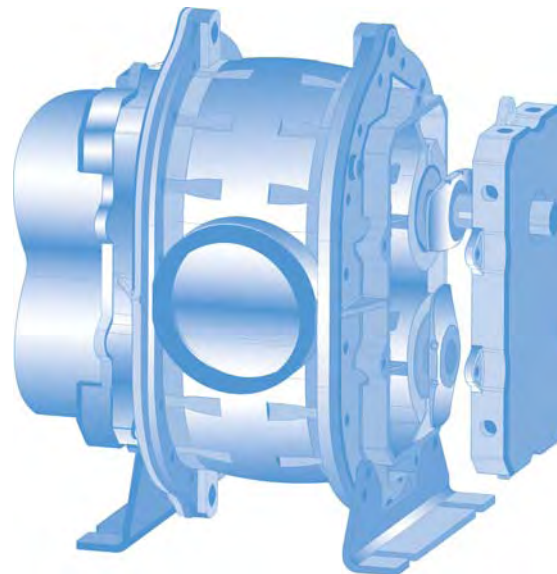
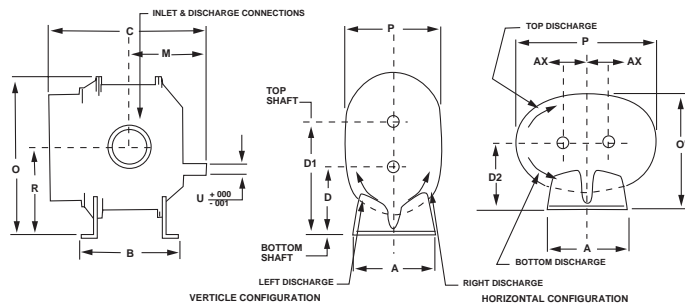

oil level confirmation. After testing, the unit is sprayed with a protective paint, and boxed or skid mounted for delivery. Available accessories include driver, relief valve, inlet and discharge silencers, inlet filter, check valve, extended base, V-belt or flexible coupling and drive guards.

OPERATING PRINCIPLE

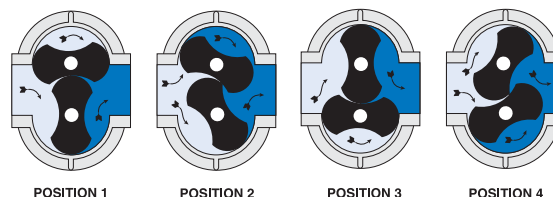

Two figure-eight lobe impellers mounted on parallel shafts rotate in opposite directions. As each impeller passes the blower inlet, it traps a definite volume of air and carries it around the case to the blower outlet, where the air is discharged. With constant speed operation, the displaced volume is essentially the same regardless of pressure or temperature.

Timing gears control the impellers relative positions and maintain small but definite clearances. This allows operation without lubrication requirements inside the unit casing.

Frame	A	A'	B	C	D	D1	D2	M	O	O'	P	P'	R	U	INLET DISCH.	AX	WGT
32	7.25	7.25	6.75	11.25	5.00	8.50	5.00	5.81	12.81	8.88	7.75	12.13	6.75	.750	1.25 NPT	1.75	72
33	7.25	7.25	7.63	12.13	5.00	8.50	5.00	6.25	12.81	8.88	7.75	12.13	6.75	.750	2.0 NPT	1.75	77
36	7.25	7.25	10.00	14.63	5.00	8.50	5.00	7.56	12.81	8.88	7.75	12.13	6.75	.750	2.5 NPT	1.75	105
42	8.00	8.00	7.25	13.00	6.25	10.25	6.25	6.86	15.06	10.63	8.75	13.63	8.25	.875	1.5 NPT	2.00	92
45	8.00	8.00	10.00	15.50	6.25	10.25	6.25	8.00	15.06	10.63	8.75	13.63	8.25	.875	2.5 NPT	2.00	113
47	8.00	8.00	11.75	17.63	6.25	10.25	6.25	9.25	15.06	10.50	8.50	13.63	8.25	.875	3.0 NPT	2.00	132
53	10.50	10.50	8.38	15.38	6.25	11.25	6.75	8.18	17.38	11.88	10.25	17.25	8.75	1.125	2.5 NPT	2.50	148
56	10.50	10.50	11.00	17.50	6.25	11.25	6.75	9.19	17.38	12.25	11.00	17.25	8.75	1.125	4.0 NPT	2.50	175
59	10.50	10.50	14.00	21.00	6.25	11.25	6.75	11.19	17.38	12.25	11.00	17.25	8.75	1.125	4.0 NPT	2.50	209
65	11.00	11.00	10.00	18.38	8.75	14.75	8.75	9.19	21.63	15.13	12.75	19.75	11.75	1.375	3.0 NPT	3.00	250
68	11.00	11.00	13.00	21.38	8.75	14.75	8.75	10.82	21.63	15.13	12.75	19.75	11.75	1.375	5.0 NPT	3.00	290
615	11.00	11.00	20.00	28.38	8.75	14.75	8.75	14.32	21.63	16.25	15.00	19.75	11.75	1.375	6.0 FLG	3.00	430



Roots

PERFORMANCE TABLE: ROOTS Universal URAI-DSL

Frame Size	Speed	4 PSI		5 PSI		6 PSI		7 PSI		8 PSI		9 PSI		10 PSI		12 PSI		13 PSI		14 PSI		15 PSI		VACUUM DATA										
		CFM	BHP	CFM	BHP	CFM	BHP	CFM	BHP	CFM	BHP	CFM	BHP	CFM	BHP	CFM	BHP	CFM	BHP	CFM	BHP	CFM	BHP	INHG	CFM	BHP								
32	1750	54	1.4	51	1.7	48	2.1	45	2.4	43	2.8	41	3.1	39	3.5	35	4.1	87	7.6	86	8.2	84	8.8	111	10.6	13	37	2.2						
	2950	108	2.4	105	3.0	102	3.6	99	4.2	97	4.7	95	5.3	93	5.9	89	7.1									15	84	4.3						
	3550	135	3.0	132	3.7	129	4.4	126	5.1	124	5.8	122	6.5	120	7.2	116	8.6									16	108	5.6						
33	1750	75	1.9	71	2.4	67	2.9	64	3.3	61	3.8	58	4.3	56	4.7	51	5.7									13	53	3.0						
	2950	149	3.3	145	4.1	141	4.9	138	5.7	135	6.5	132	7.3	130	8.1	125	9.7									15	119	5.9						
	3550	186	4.1	182	5.0	178	6.0	175	6.9	172	7.9	169	8.8	167	9.8	162	11.7									15	156	7.2						
36	1750	132	3.2	126	3.9	121	4.7	117	5.5																	14	95	5.4						
	2950	254	5.5	249	6.8	244	8.1	239	9.4																	15	212	9.8						
	3550	316	6.7	310	8.3	305	9.9	300	11.5																	15	273	11.9						
42	1750	78	1.9	74	2.4	71	2.8	69	3.3	66	3.7	64	4.2	61	4.7	57	5.6	55	6.0	126	11.1	124	11.9	160	14.4	14	55	3.2						
	2950	150	3.3	147	4.1	144	4.9	141	5.7	139	6.5	136	7.2	134	8.0	130	9.6									16	121	6.2						
	3550	187	4.1	183	5.1	180	6.0	177	7.0	175	7.9	172	8.8	170	9.8	166	11.6									16	157	7.6						
45	1750	161	3.8	155	4.7	150	5.6	145	6.6	140	7.5	136	8.4	132	9.3											14	121	6.4						
	2950	306	6.7	300	8.2	295	9.8	290	11.3	285	12.9	281	14.4	277	16.0											16	253	12.5						
	3550	379	8.2	373	10.1	368	12.0	363	13.9	358	15.7	354	17.6	349	19.5											16	326	15.2						
47	1750	215	5.0	208	6.2	201	7.4	195	8.6																	14	165	8.4						
	2950	407	8.8	399	10.8	392	12.9	386	14.9																	15	348	15.4						
	3550	502	10.9	495	13.3	488	15.8	482	18.3																	15	444	18.8						
53	1170	113	2.7	108	3.4	103	4.1	99	4.8	96	5.4	92	6.1	89	6.8	82	8.1	156	13.3	153	14.3					13	85	4.3						
	1750	189	4.2	184	5.2	180	6.2	176	7.2	172	8.2	168	9.2	165	10.3	159	12.3									15	151	7.5						
	2850	334	7.4	329	9.0	325	10.7	321	12.3	317	14.0	313	15.6	310	17.2	304	20.5									301	22.1	298	23.8	295	25.4	16	291	13.4
56	1170	196	4.6	188	5.7	182	6.9	175	8.0	170	9.1	164	10.2	159	11.4	150	13.6	273	22.2							14	146	7.8						
	1750	324	7.0	316	8.7	310	10.4	304	12.1	298	13.8	292	15.5	287	17.2	278	20.5									273	22.2	15	266	12.6				
	2850	567	12.2	560	15.0	553	17.7	547	20.5	541	23.2	536	26.0	530	28.7	521	34.2									517	37.0	16	501	22.4				
59	1170	299	6.7	290	8.4	281	10.0	273	11.7																	14	237	11.4						
	1750	486	10.3	477	12.8	469	15.2	461	17.7																	15	414	18.4						
	2850	842	18.0	832	22.0	824	26.0	816	30.0																	15	770	30.8						
65	1170	223	5.2	215	6.4	208	7.7	202	8.9	196	10.2	190	11.5	185	12.7	175	15.2	171	16.5	166	17.7					14	171	8.7						
	1750	365	8.0	358	9.9	351	11.8	344	13.7	339	15.6	333	17.4	328	19.3	318	23.1									313	24.9	309	26.8	305	28.7	16	297	15.1
	2350	513	11.4	505	13.9	489	16.4	492	19.0	486	21.5	481	24.0	475	26.5	465	31.6									461	34.1	456	36.6	452	39.1	16	445	20.6
68	1170	358	8.3	345	10.3	334	12.3	324	14.3	314	16.3	305	18.3	297	20.3	281	24.4	274	26.4	267	28.4					14	275	13.9						
	1750	587	12.7	574	15.7	563	18.7	553	21.8	544	24.8	535	27.8	526	30.8	510	36.8									503	39.8	496	42.9	16	478	24.0		
	2350	824	17.8	811	21.8	800	25.9	790	29.9	781	34.0	772	38.0	763	42.1	747	50.2									740	54.2	733	58.3	16	715	32.8		
615	1170	670	15.4	647	19.1	626	22.9	607	26.7																	11	581	20.5						
	1750	1099	23.4	1076	29.1	1055	34.7	1036	40.4																	12	989	33.7						
	2350	1543	32.4	1520	40.0	1499	47.6	1480	55.2																	12	1433	46.0						

NOTES: 1. Performance based on inlet air at standard pressure of 14.7 psia, standard temperature of 68° F, and specific gravity of 1.0.
 2. Vacuum ratings based on inlet air at standard temperature of 68° F, discharge pressure of 30" Hg and specific gravity of 1.0.

DESIGN AND CONSTRUCTION FEATURES

- 1. Detachable steel mounting feet
- 2. Rigid one-piece cast iron casing
- 3. Anti-friction bearings
- 4. Splash oil lubricated spur timing gears
- 5. Connections in standard pipe sizes
- 6. Ground steel shafts
- 7. Straight, precision machined two precision machined two-lobe impellers



Roots

Dresser ROOTS

2136 Hwy 6 South
 Houston, TX 77077
 Ph: 281-966-4700
 Fx: 281-966-4309
 Toll Free (US): 877-363-ROOT(S)

Dresser ROOTS

Connersville
 900 West Mount Street
 Connersville, IN 47331
 Ph: 765-827-9200
 Fx: 765-827-9266

Dresser ROOTS

Holmes Operation
 PO Box B7
 Off St. Andrews Rd
 Turnbridge, Huddersfield
 England HD1 6RB
 Ph: +44-1484-422222
 Fx: +44-1484-422668

Copyright 2003 Dresser, Inc. All rights reserved.
 Dresser Design and Universal RAI DSL® are registered trademarks of Dresser, Inc.
 ROOTS™ is a trademark of Dresser, Inc.
 All information subject to change without notice.

website: www.rootsblower.com ♦ email: ROOTS@dresser.com



PERFORMANCE BASED ON AIR,
 INLET AT 14.7 PSIA & 68°F
 DECEMBER 2004

PRESSURE PERFORMANCE
FRAME 42 U-RAI
 MAX. PRESSURE RISE = 15 PSI
 MAX. SPEED = 3600 RPM

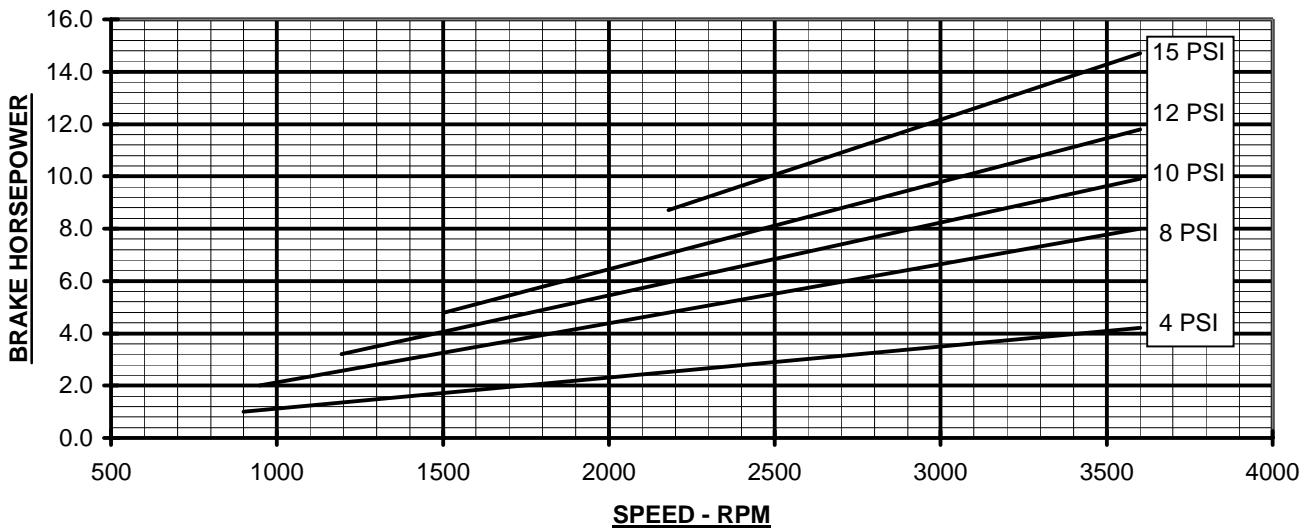
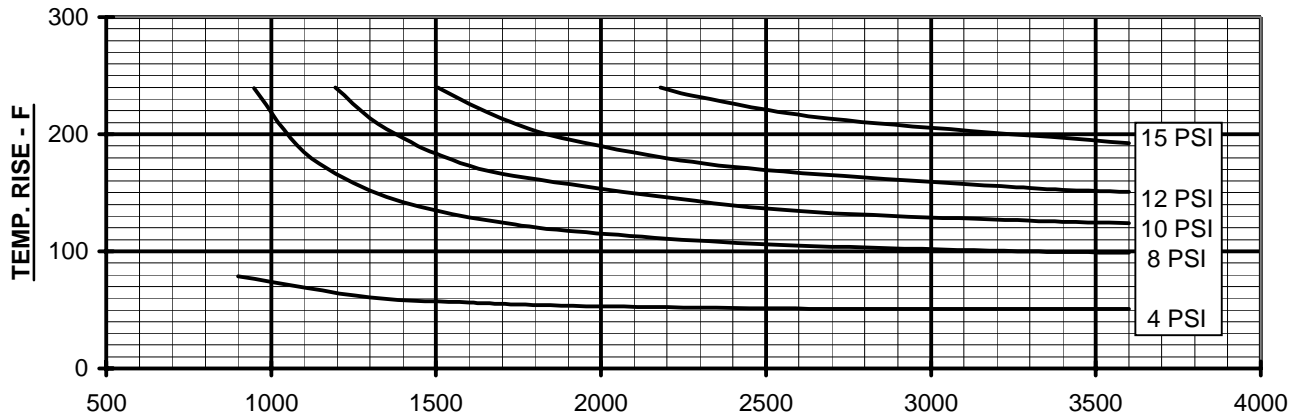
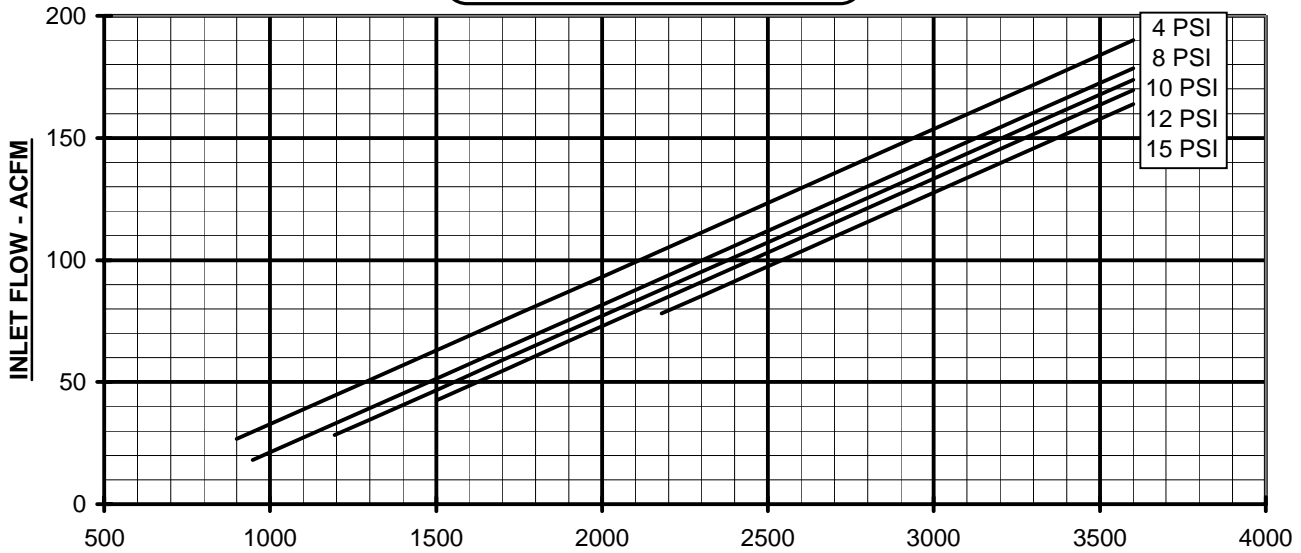



VACUUM PERFORMANCE
FRAME 42 U-RAI
 MAX. VACUUM = 16" HG
 MAX. SPEED = 3600 RPM

PERFORMANCE BASED ON AIR,
 INLET AT 68°F
 DISCHARGE PRESSURE = 30" HG ABS.
 DECEMBER 2004

