



Roots

615 URAI-GAS

Part Number – 651180G0



- Detachable steel mounting feet (feet are different for horizontal and vertical mounting)
- Mechanical Seals
- Rigid one-piece cast iron casing
- Connections in standard pipe sizes
- Straight, precision machined two-lobe impellers
- Splash oil lubricated gears
- Carburized and ground alloy steel spur timing gears
- Anti-Friction gears
- Ground steel shafts
- Center Timed for rotation in either direction

Also Available in:

- URAI
- URAI-DSL (Dual Splash Lube)
- URAI-Metric



816-741-0282



Quick Specs

Flow Range	to 1583 CFM
Max Δ Pressure	7 PSI
Max Δ Vacuum	12" Hg
Maximum RPM	2350
Minimum RPM	636
Max Δ T	130°F
Connection Size	6" Flange
Shaft Dia.	1.375"
Min Sheave Dia.	8"
Drive End Lubrication	Grease
Gear End Lubrication	Oil
Oil Sump Gear End Horiz Config	~52 oz
Oil Sump Gear End Vert Config	~28.3 oz
Bare Unit Weight	425 lbs
Container	Wood Skid
Skid Size (L x W x H)	54" x 32" x 25"
Shipping Weight on Skid	~470 lbs
Recommended to Ship Via	Truck

**Universal RAI Series Gas Blowers Parts List
6" Gear Diameter**

(Refer to drawing #T3011023)



816-741-0282

Item Number	Part Name	Quantity
1	Headplate Gear End	1
2	Headplate Drive End	1
3	Gearbox	1
4	Timing Gears	2
5	Cover-Blind (Plug Opening)	1
7	Gasket, Gear Box	1
7*	Gasket DE Cover	1
11	Cylinder	1
12	Impeller & Shaft Drive	1
13	Impeller & Shaft Driven	1
14	Bearing, Ball	3
15	Bearing, Roller	1
16	Pin, Dowel	4
17	Gear Nut	2
19	Key	1
21	Plug, Pipe	3
23	Screw Hex Nylock	8
25	Breather (Plug Vent)	1
26	Screw, Hex	14**
27	Seal, Bearing	4
31	Screw, Hex	4
32	Screw, Hex	10
33	Seal Lip-Drive	1
34	Clamp Plate	2
35	Foot	2
37	Fitting, Grease	2
38	Fitting, Relief	2
39	Washer Mounting	4
40	Screw Socket	2
42	Screw Hex	2
43	Plug	8
51	Shoulder Bolt	2
53	Oil Sight Glass	2

*DE cover gasket is not the same as the gasket used on the GE. You must specify the gasket required when ordering.

**Quantities vary by blower.

URAI GAS blower grease specifications.

- When servicing drive end bearings of a URAI GAS blower, use the specified NLGI #2 premium grade aluminum complex* grease, ROOTS P/N T20019001.
- Lithium based greases are not compatible with the specified and recommended ROOTS Synthetic grease used when assembling a GAS blower. **Lithium based grease is not approved for any ROOTS blowers.**

Table 2 - Recommended Oil Grades

Ambient* Temperature °F (°C)	ISO Viscosity No.
Above 90° (32°)	320
32° to 90° (0° to 32°)	220
0° to 32° (-18° to 0°)	150
Below 0° (-18°)	100

*Ambient temperature is defined as the temperature of the space in which the blower and drive are located.

Repair Kits

Repair kits are bundled with the parts you need to complete a standard repair. It is more cost effective to buy a repair kit than to purchase individual parts. However, if you need parts not listed in the kit, it is recommended that you call Pathfinder Systems for parts pricing.

P/N 65115GRK Kit without Gears for 65, 68, 615 URAI-GAS

Item	Qty	6" Kit Description	P/N
5	1	PLUG,OPENING	12957005
7	1	GSKT,GRBX 6 URAI TS9003	62745021
14	3	BRG,BALL	10987042
15	1	BRG,ROLLER	10222033
17	2	NUT,HEX ESNA 1 1/8-12	10319021
27	4	MECHANICAL SEAL	T20002004
29	2	WSHR,SPR WAVY	10135004
31	4	SCR,CAP HEXH NYL	10677012
33	1	SEAL,LIP (BUNA-N)	12877001
38	4	PLUG, VENT 1/8"	13002001
44	1	SHIM SET 6" URAI-G	T30126020

P/N 65114GRK Kit with Gears for 65, 68, 615 URAI-GAS

Item	Qty	6" Kit Description	P/N
4	1	GEAR, ASSY 6 URAI	64910021
5	1	PLUG,OPENING	12957005
7	1	GSKT,GRBX 6 URAI TS9003	62745021
14	3	BRG,BALL	10987042
15	1	BRG,ROLLER	10222033
17	2	NUT,HEX ESNA 1 1/8-12	10319021
27	4	MECHANICAL SEAL	T20002004
29	2	WSHR,SPR WAVY	10135004
31	4	SCR,CAP HEXH NYL	10677012
33	1	SEAL,LIP (BUNA-N)	12877001
38	2	PLUG, VENT 1/8"	13002001
44	1	SHIM SET 6" URAI-G	T30126020

ROOTS® Synthetic Oil: ISO-VG-320 Grade

	Part Number
Quart	13106004
Gallon	13106005
Case (12 qts)	13106007

ROOTS® Synthetic Oil: ISO-VG-220 Grade

	Part Number
Quart	13106001
Gallon	13106002
Case (12 qts)	13106008

ROOTS® Synthetic Oil: ISO-VG-150 Grade

	Part Number
Quart	13106020
Gallon	13106021
Case (12 qts)	13106023
5 Gallon Pail	13106022
55 Gallon Drum	13106025

ROOTS® Synthetic Oil: ISO-VG-100 Grade

	Part Number
Quart	13106011
Gallon	13106012
Case (12 qts)	13106014
5 Gallon Pail	13106013
55 Gallon Drum	13106016

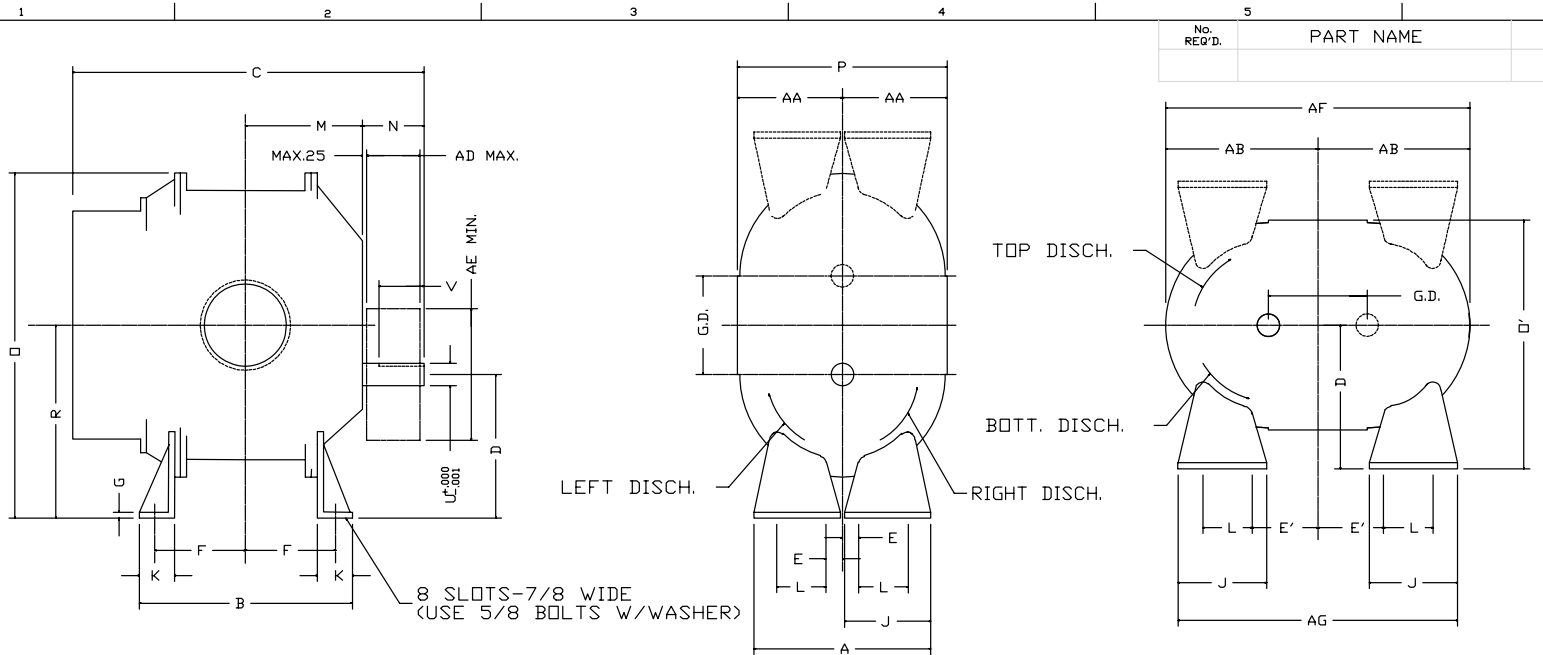

8 SLOTS-7/8 WIDE
(USE 5/8 BOLTS W/WASHER)

No. REQ'D.	PART NAME	PATT. No. PART No.	MAT'L.
------------	-----------	--------------------	--------

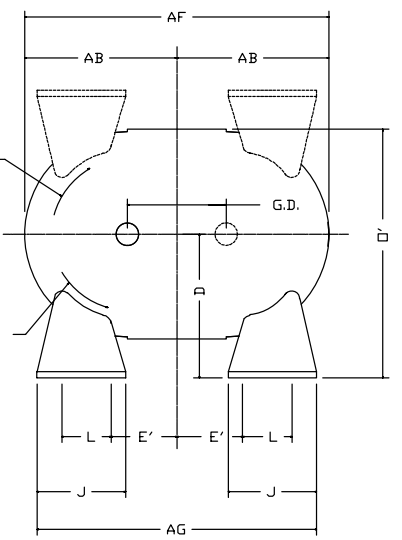

W-INLET
W'-DISCHARGE
AD-SHEAVE WIDTH
AE-SHEAVE DIA.
ALL DIM. IN INCHES

	6"FLG	8"FLG		
OPENING	6.00	8.00		
BOLT CIRCLE	9.50	11.75		
FLANGE O.D.	11.00	13.50		
NO. TAPPED HOLES	8	8		
SIZE HOLES	3/4-10	3/4-10		
TAP DEPTH	1.13	1.13		

UNIT SIZE	APPROX. OIL CAP.		
	VERT.	HORIZ.	G.D.
6"	28.3 FL OZ	52.1 FL OZ	6.00
7"	32.3 FL OZ	59.5 FL OZ	7.00

FRAME SIZE	A	B	C	D	E	E'	F	G	J	K	L	M	N	O	O'	P	R	U	V	KEYWAY	W	W'	AA	AB	AD	AE	AF	AG	APPROX WEIGHT
65	11.00	10.00	18.38	8.75	1.00	4.00	3.81	.38	5.38	2.13	3.00	5.63	3.56	21.63	15.13	12.75	11.75	1.375	2.75	.312x.156	3"NPT	3"NPT	6.38	9.88	3.44	8.00	19.75	17.00	245 LBS
68		13.00	21.38				5.81					7.13	3.69								5"NPT	5"NPT							285 LBS
615		20.00	28.38				8.81					10.63			16.25	15.00					6"FLG	6"FLG	7.50						425 LBS
76	14.00	11.75	19.94	11.00	2.00	5.50	4.88	.50	6.75	2.38	3.50	5.94	4.06	26.13	20.69	19.38	14.5	1.562	3.00	.375x.188	4"NPT	4"NPT	9.69	11.63	3.75	9.50	23.25	21.00	400 LBS
711		16.75	25.19				7.38					8.44	4.31		19.50	17.00					6"FLG	6"FLG	8.50						530 LBS
718		23.75	32.19				10.88					11.94									8"FLG	8"FLG							650 LBS

MFG. REF. _____ DATE _____

CONFIDENTIAL

THIS DOCUMENT CONTAINS CONFIDENTIAL INFORMATION OF ROOTS DIVISION, DRESSER INDUSTRIES, INC. IT SHALL BE HELD IN STRICTEST CONFIDENCE, AND BE USED ONLY IN CONJUNCTION WITH ROOTS DIVISION BUSINESS.

REF: EP938

CONCENTRICITY

FLATNESS

PERPENDICULARITY

ANGULARITY

PROFILE OF LINE

PARALLELISM

PROFILE OF A SURFACE

TRUE POSITION

DIAMETER

STRAIGHTNESS

FINISH IN MICRO INCHES

G REF 'F' DIM ON 68 RDR 6459V

F BOLTS CLARIFIED DB

REVISIONS

BY _____ DATE _____ CHANGE NOTICE _____ CHKD. _____ APP _____

DO NOT SCALE FOR DIMENSIONS
ALL DIMENSIONS SHOWN IN BRACKETS () ARE MILLIMETERS

ORDER No. _____

UNIVERSAL RAI BLOWER

ROOTS DIVISION
DRESSER EQUIPMENT GROUP
A HALLIBURTON COMPANY
HOUSTON, TX USA

DIMENSIONAL TOLERANCES UNLESS OTHERWISE SPECIFIED
FINISHED DIMENSIONS
TWO PLACE DECIMALS .000--.0015 FRACTIONAL--11/64
THREE PLACE DECIMALS .000--0.005

62753021

REV G

ROOTS™ Universal RAI®-G Rotary Positive Gas Blowers

Frames 32 thru 615



BASIC BLOWER DESCRIPTION

Universal RAI®-G gas blowers are heavy duty rotary blowers designed with mechanical seals. The detachable rugged steel mounting feet, permit adaptability to either vertical or horizontal installation requirements. The compact, sturdy design is engineered for continuous service when operated in accordance with speed and pressure ratings.

The basic model consists of a cast iron casing, carburized and ground alloy steel spur timing gears secured to steel shafts with a taper mounting and locknut, and cast iron involute impellers. Oversized anti-friction bearings are used, with a cylindrical roller bearing at the drive shaft to withstand V-belt pull. The Universal RAI®-G features splash oil lube on the gear end and grease lube on the drive end.

Accessories are available through our distributors.

ROOTS™ Synthetic Oil and grease is recommended to maintain warranty.

DESIGN AND CONSTRUCTION FEATURES

1. Mechanical seals
2. Rigid one-piece cast iron casing
3. Anti-friction bearings
4. Splash oil lubricated spur timing gears
5. Connections in standard pipe sizes
6. Straight, precision machined two-lobe impellers
7. Ground steel shafts
8. Detachable steel mounting feet

OUTLINE DRAWING & DIMENSIONAL TABLE

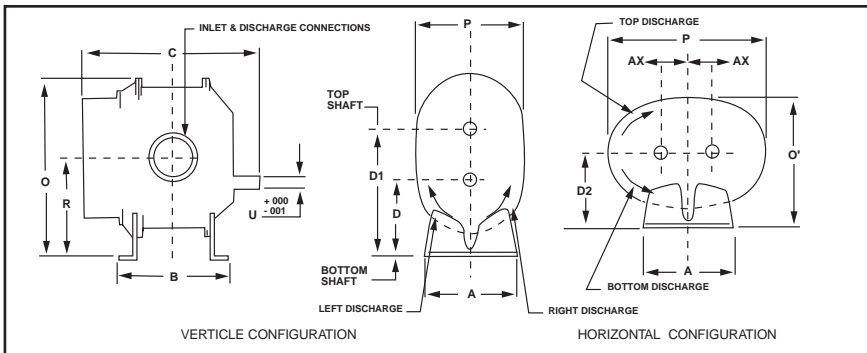

Frame Size	A	B	C	Drive Shaft Location			O	O'	P	P'	R	U	Keyway	Inlet & Disch. Dia	AX	Approx. Net Wt. (lbs.)
				D	D1	D2										
32	7.25	6.75	11.25	5.00	8.50	5.00	12.81	8.88	7.75	12.13	6.75	.750	.188 x .094	1.25 NPT	1.75	69
33	7.25	7.63	12.13	5.00	8.50	5.00	12.81	8.88	7.75	12.13	6.75	.750	.188 x .094	2.0 NPT	1.75	74
36	7.25	10.00	14.63	5.00	8.50	5.00	12.81	8.88	7.75	12.13	6.75	.750	.188 x .094	2.5 NPT	1.75	102
42	8.00	7.25	13.00	6.25	10.25	6.25	15.06	10.63	8.75	13.63	8.25	.875	.188 x .094	1.5 NPT	2.00	88
45	8.00	10.00	15.50	6.25	10.25	6.25	15.06	10.63	8.75	13.63	8.25	.875	.188 x .094	2.5 NPT	2.00	109
47	8.00	11.75	17.63	6.25	10.25	6.25	15.06	10.50	8.50	13.63	8.25	.875	.188 x .094	3.0 NPT	2.00	128
53	10.50	8.38	15.38	6.25	11.25	6.75	17.38	11.88	10.25	17.25	8.75	1.125	.250 x .125	2.5 NPT	2.50	143
56	10.50	11.00	18.00	6.25	11.25	6.75	17.38	12.25	11.00	17.25	8.75	1.125	.250 x .125	4.0 NPT	2.50	170
59	10.50	14.00	21.18	6.25	11.25	6.75	17.38	12.25	11.00	17.25	8.75	1.125	.250 x .125	4.0 NPT	2.50	204
65	11.00*	10.00	18.38	8.75	14.75	8.75	21.63	15.13	12.75	19.75	11.75	1.375	.312 x .156	3.0 NPT	3.00	245
68	11.00*	13.00	21.38	8.75	14.75	8.75	21.63	15.13	12.75	19.75	11.75	1.375	.312 x .156	5.0 NPT	3.00	285
615	11.00*	20.00	28.38	8.75	14.75	8.75	21.63	16.25	15.00	19.75	11.75	1.375	.312 x .156	6.0 FLG	3.00	425

OPERATING PRINCIPLE

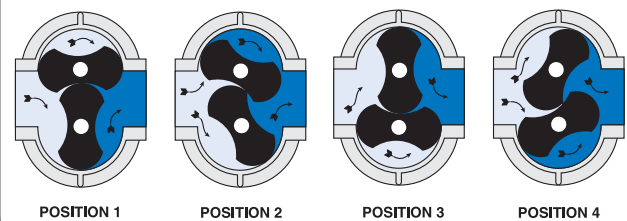

Two figure-eight lobe impellers mounted on parallel shafts rotate in opposite directions. As each impeller passes the blower inlet, it traps a definite volume of gas and carries it around the case to the blower outlet, where the gas is discharged. With constant speed operation, the displaced volume is essentially the same regardless of pressure, temperature or barometric pressure.

Timing gears control the relative position of the impellers to each other and maintain small but definite clearances. This allows operation without lubrication being required inside the gas casing.



PERFORMANCE TABLE

FRAME	SPEED	1 PSI		2 PSI		3 PSI		4 PSI		5 PSI		6 PSI		7 PSI		8 PSI		10 PSI		11 PSI		12 PSI		13 PSI		14 PSI		15PSI		Max. Vacuum		
		SIZE	RPM	CFM	BHP	CFM	BHP	CFM	BHP	CFM	BHP	CFM	BHP	CFM	BHP	CFM	BHP	CFM	BHP	CFM	BHP	CFM	BHP	CFM	BHP	CFM	BHP	CFM	BHP	*HG	CFM	BHP
32	1200	37	0.2	30	0.4	24	0.7	20	0.9	16	1.1	12	1.4																	8	15	0.9
	1800	64	0.4	57	0.8	51	1.1	47	1.5	43	1.8	39	2.2																10	35	1.7	
	2500	95	0.6	88	1.1	83	1.6	78	2.1	74	2.5	71	3.0																13	56	3.2	
	3600	145	0.9	138	1.6	133	2.3	128	3.0	124	3.7	120	4.4																16	93	5.7	
33	1200	52	0.3	42	0.6	36	1.0	29.6	1.3	24	1.6	20	1.9																	8	23	1.3
	1800	89	0.5	80	1.0	72	1.5	66.5	1.9	61	2.4	57	2.9																	10	51	2.4
	2500	132	0.9	123	1.5	116	2.2	110	2.9	104	3.5	100	4.2																	13	80	4.3
	3600	200	1.2	190	2.1	183	3.1	177	4.1	172	5.0	167	6.0																	15	137	7.3
36	1200	91	0.6	78	1.1	68	1.6	60	2.2	52	2.7	46	3.2																	8	50	2.1
	1800	152	0.9	139	1.7	129	2.5	121	3.3	113	4.1	107	4.9																	10	99	4.0
	2500	224	1.3	211	2.5	201	3.6	192	4.7	185	5.8	178	6.9																	13	150	7.2
	3600	336	2.1	323	3.7	313	5.3	304	6.9	297	8.5	290	10.1																	15	248	12.1
42	1200	54	0.3	46	0.6	40	0.9	35	1.3	30	1.6	26	1.9																	8	29	1.3
	1800	90	0.6	82	1.0	76	1.5	71	2.0	66	2.5	62	2.9																	10	58	2.4
	2500	132	0.8	124	1.5	118	2.2	113	2.8	109	3.5	105	4.1																	13	88	4.3
	3600	199	1.4	191	2.4	185	3.3	180	4.3	175	5.2	171	6.2																	16	140	7.7
45	1200	111	0.7	97	1.3	86	2.0	77	2.6	69	3.2	61	3.9																	8	67	2.5
	1800	184	1.0	170	2.0	159	2.9	150	3.9	142	4.8	134	5.8																	10	126	4.7
	2500	268	1.6	254	3.0	243	4.3	234	5.6	226	6.9	219	8.2																	13	189	8.6
	3600	402	2.7	387	4.6	377	6.5	367	8.4	359	10.3	352	12.2																	16	297	15.4
47	1200	148	0.9	131	1.7	117	2.5	105	3.4	95	4.2	86	5.0																	8	92	3.3
	1800	244	1.4	226	2.6	213	3.9	201	5.1	191	6.4	182	7.6																	10	171	6.2
	2500	356	2.1	338	3.8	324	5.6	313	7.3	303	9.1	293	10.8																	13	255	11.3
	3600	531	3.6	513	6.1	500	8.6	488	11.1	478	13.6	469	16.1																	15	410	19.1
53	800	77	0.4	66	0.9	57	1.3	49	1.8	43	2.2	37	2.7																	8	41	1.8
	1400	157	0.9	145	1.7	136	2.5	129	3.3	122	4.1	116	4.9																	10	109	4.0
	1800	209	1.3	198	2.3	189	3.4	181	4.4	175	5.4	169	6.5																	13	144	6.7
	2850	348	2.5	336	4.2	327	5.8	320	7.5	313	9.1	307	10.7																	16	262	13.4
56	800	134	0.8	117	1.5	104	2.3	92	3.1	82	3.9	73	4.6																	8	79	3.0
	1400	267	1.6	250	2.9	236	4.3	225	5.6	215	6.9	206	8.3																	10	195	6.7
	1800	355	2.1	338	3.9	325	5.6	313	7.3	303	9.1	294	10.8																	13	257	11.2
	2850	588	4.0	570	6.8	557	9.5	545	12.3	535	15.0	526	17.8																	16	457	22.4
59	800	205	1.2	183	2.4	166	3.5	152	4.6	137	5.7	128	6.9																	8	136	4.4
	1400	399	2.3	377	4.3	360	6.2	346	8.2	333	10.2	322	12.1																	10	309	9.8
	1800	528	3.1	506	5.6	489	8.1	475	10.7	462	13.2	451	15.7																	13	404	16.5
	2850	867	5.9	845	9.9	828	13.9	814	18.0	802	22.0	790	26.0																	15	718	30.8
65	700	128	0.8	110	1.5	96	2.3	85	3.0	74	3.8	65	4.5																	8	71	3.0
	1400	301	1.8	282	3.3	269	4.8	257	6.3	246	7.8	237	9.3																	10	226	7.5
	1800	399	2.5	381	4.4	367	6.4	355	8.3	345	10.2	336	12.2																	13	297	12.7
	2350	534	3.8	516	6.3	502	8.9	491	11.4	480	13.9	471	16.4																	16	400	20.6
68	700	206	1.2	177	2.5	155	3.7	136	4.9	119	6.1	104	7.3																	8	115	4.8
	1400	483	2.7	454	5.2	431	7.6	412	10.0	396	12.4	381	14.8																	10	363	12.0
	1800	641	3.8	612	6.9	589	10.0	570	13.1	554	16.2	539	19.3																	13	477	20.2
	2350	858	5.6	829	9.7	806	13.7	788	17.8	771	21.8	756	26.2																	16	642	32.8
615	700	386	2.3	332	4.6	290	6.8	255	9.0	223	11.3																			8	215	8.9
	1400	904	5.0	850	9.5	808	14.0	773	18.5	741	23.0																			10	681	22.4
	1800	1200	6.7	1146	12.6	1104	18.4	1069	24.2	1037	30.0																			12	922	34.7
	2350	1607	9.7	1553	17.3	1511	24.8	1476	32.4	1444	40.0																			13	1300	49.7

Notes: 1. Performance based on inlet methane at standard pressure of 14.7 psia, standard temperature of 68°F, and specific gravity of 0.55.
 2. Vacuum ratings based on inlet methane at standard temperature of 68°F, discharge pressure of 30" Hg and specific gravity of 0.55.



Roots

S-60A01
December 2002

©2002 Dresser, Inc.
 ROOTS is a trademark of Dresser, Inc.
 Dresser Design and Universal RAI are registered trademarks of Dresser, Inc.

Dresser ROOTS
 2135 Hwy 6 South
 Houston, TX 77077
 PH: 281-966-4700
 FX: 281-966-4309
 Toll Free: 1-877-363-ROOT(S)

Dresser ROOTS - Connorsville
 900 West Mount Street
 Connorsville, IN 47331
 PH: 765-827-9200
 FX: 765-827-9266

Dresser ROOTS - Holmes Operation
 PO Box B7
 Off St. Andrews Rd
 Turnbridge, Huddersfield
 England HD1 6RB
 PH: +44-1484-422222
 FX: +44-1484-4226



PERFORMANCE BASED ON AIR,
 INLET AT 14.7 PSIA & 68°F
 DECEMBER 2004

PRESSURE PERFORMANCE
FRAME 615 U-RAI
 MAX. PRESSURE RISE = 7 PSI
 MAX. SPEED = 2350 RPM

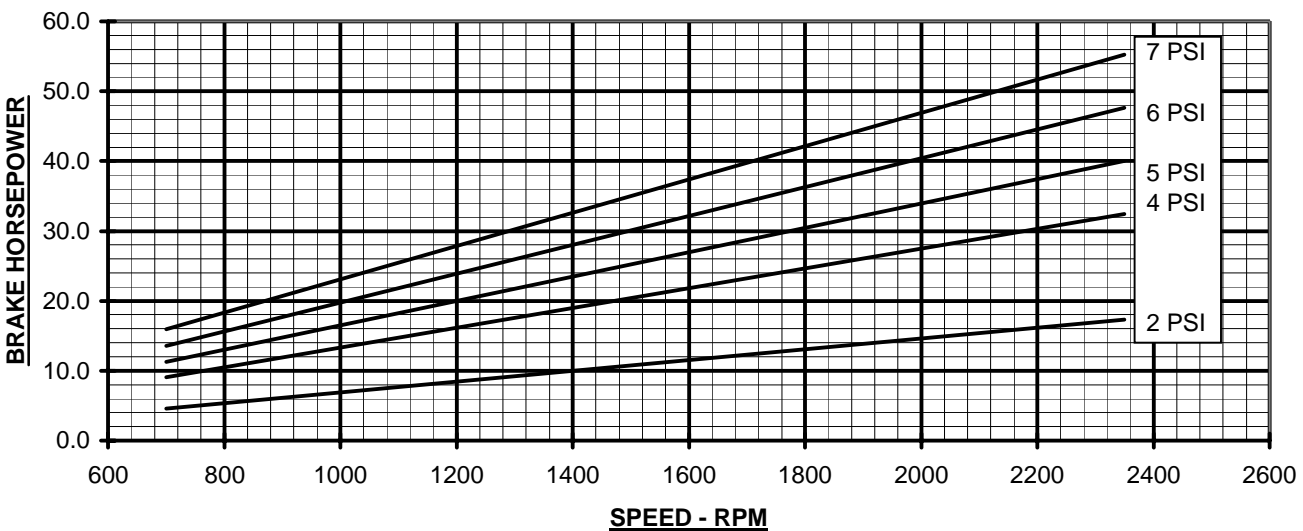
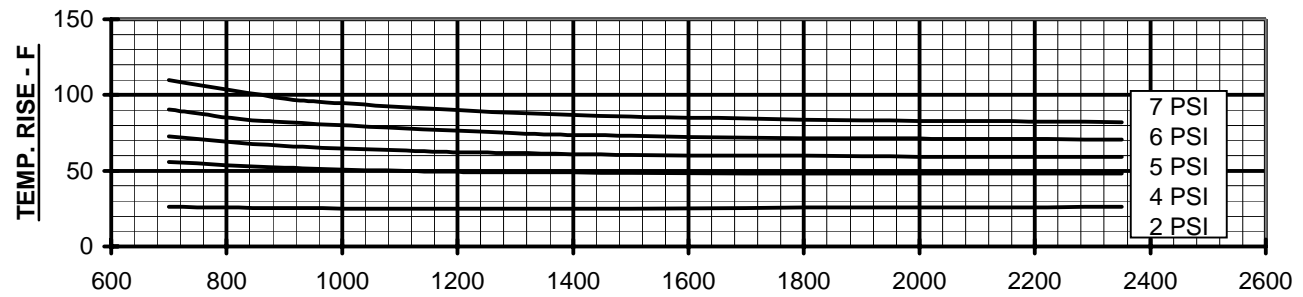
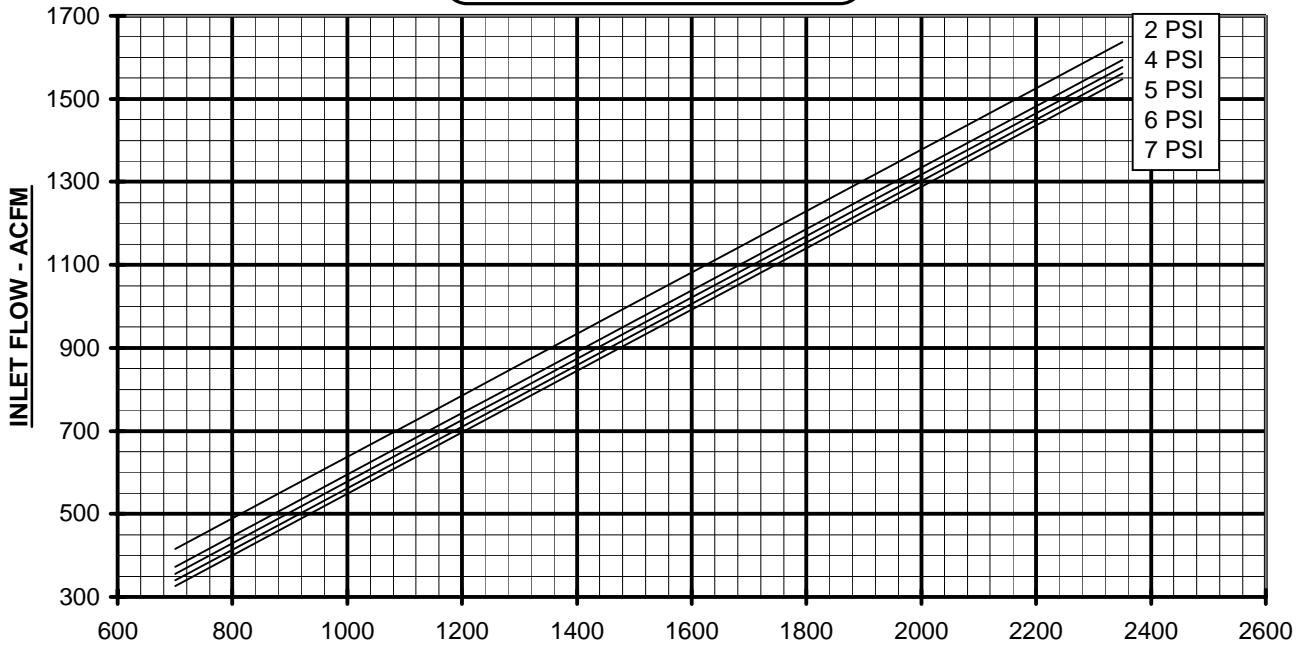



VACUUM PERFORMANCE
FRAME 615 U-RAI
 MAX. VACUUM = 12" HG
 MAX. SPEED = 2350 RPM

PERFORMANCE BASED ON AIR,
 INLET AT 68°F
 DISCHARGE PRESSURE = 30" HG ABS.
 DECEMBER 2004

