

**Parts Identification**

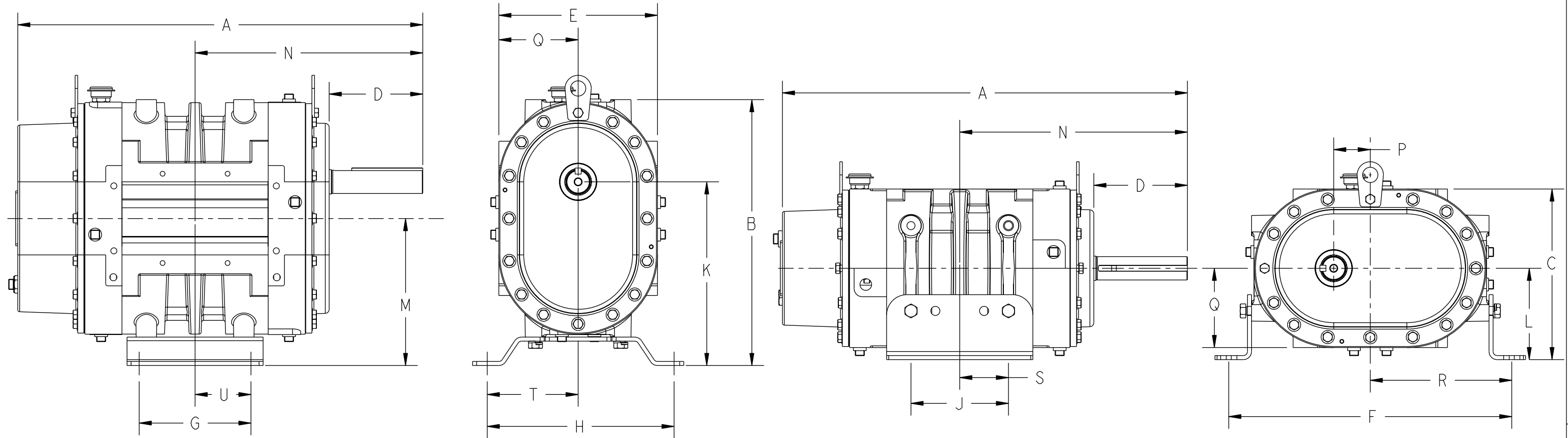

FRAME	A	B	C	D	E	F	G	H	J	K	L	M	N	P	Q	R	S	T	U	W	KEY WAY	WGT
404	18.43	16.37	10.5	4.26	9.75	17.5	4.88	11.5	5.0	11.3	5.62	9.1	10.02	2.25	4.88	8.75	2.5	5.75	2.44	1.44	.376 X.21	200
406	21.93	16.37	10.5	5.76	9.75	17.5	6.88	11.5	7.0	11.3	5.62	9.1	12.52	2.25	4.88	8.75	3.5	5.75	3.44	1.44	.376 X.21	240
409	24.93	16.37	10.5	5.76	9.75	17.5	6.88	11.5	7.0	11.3	5.62	9.1	14.02	2.25	4.88	8.75	3.5	5.75	3.44	1.44	.376 X.21	280
412	27.93	16.37	10.5	5.76	9.75	17.5	9.88	11.5	10.0	11.3	5.62	9.1	15.52	2.25	4.88	8.75	5.0	5.75	4.94	1.44	.376 X.21	330

FRAME	INLET AND DISCHARGE CONNECTIONS	MOUNTING BOLT HOLE DIAMETER
404	4" NPT	0.69
406	4" NPT	0.69
409	4" OR 5" NPT	0.69
412	6" NPT	0.69

REV. NO.	REVISIONS	BY	DATE	ECO. NO.	CHKD.	APPD.

<p><b>CONFIDENTIAL</b></p> <p>THIS DOCUMENT CONTAINS CONFIDENTIAL INFORMATION OF DMD-ROOTS DIVISION, DRESSER EQUIPMENT GROUP. IT SHALL BE HELD IN STRICTEST CONFIDENCE, AND BE USED ONLY IN CONJUNCTION WITH DMD-ROOTS DIVISION BUSINESS.</p>	<p>DO NOT SCALE PRINTS. REMOVE BURRS. BREAK ALL SHARP EDGES. DIMENSIONS SHOWN IN [ ] ARE MILLIMETERS. ALL FINISHED SURFACES TO BE 125 UNLESS SPECIFIED.</p>	<p>TOLERANCES UNLESS OTHERWISE SPECIFIED</p>		<p>TITLE</p> <p>ASSEMBLY, TOP LEVEL</p> <p>400 ROOTS-FLO</p>				
		<p>DIM</p> <p>.XX ±.01</p> <p>.XXX ±.005</p> <p>X/X ±1/64</p> <p>X° ±30'</p>	<p>DIM</p> <p>.XXX ±.005</p> <p>X/X ±1/64</p> <p>X° ±30'</p>	<p><b>DRESSER</b> <b>DMD ROOTS</b></p>		<p>DMD-Roots Division DRESSER EQUIPMENT GROUP, INC. HOUSTON, TX, USA</p>		
<p>⊥ PERPENDICULARITY</p> <p>⊕ TRUE POSITION</p> <p>◎ CONCENTRICITY</p> <p>— STRAIGHTNESS</p> <p>Ⓜ PROFILE OF LINE</p> <p>Ⓜ MAX. MATERIAL CONDITION</p> <p>√ FINISH IN MICRO INCHES REGARDLESS OF FEATURE SIZE</p> <p>Ⓢ INDICATING MACHINE LOCATING SURFACE</p>	<p>○ ROUNDNESS</p> <p>— FLATNESS</p> <p>∥ PARALLELISM</p> <p>∠ RUNOUT</p> <p>Ⓜ PROFILE OF SURFACE</p> <p>∅ DIAMETER</p> <p>∠ ANGULARITY</p>	<p>PATTERN NO.</p> <p>REF. NO.</p> <p>NEXT ASSY.</p>	<p>SCALE</p> <p>1:6</p> <p>SHEET</p> <p>1 OF 1</p>	<p>DRAWN BY</p> <p>TS</p>	<p>CHECKED</p> <p>DATE</p>	<p>APPROVED</p> <p>WEIGHT</p> <p>280.0</p>	<p>DRAWING NUMBER</p> <p>T30003021</p>	<p>REV.</p>