

700 Series RCS-J and DVJ Blowers

Installation, Operation & Maintenance

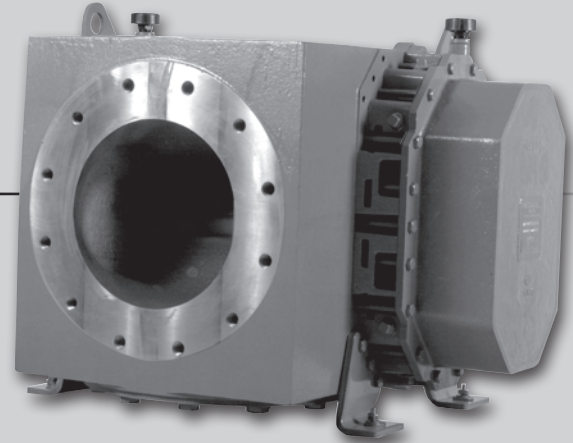

Contents

GENERAL INFORMATION	1 - 10	Inspection & Maintenance.....	11
Information Summary	1	RCS-J SECTION	12 - 16
Safety Precautions.....	3	Parts List	13
Operating Limitations.....	3	Drawings	14 - 16
Installation	4 - 7	DVJ SECTION	17 - 23
Lubrication	8	Parts List	20
Operation	9	Drawings	21 - 23
Troubleshooting.....	10		

Do These Things To Get The Most From Your ROOTS™ blower

- Check shipment for damage. If found, file claim with carrier and notify Roots.
- Unpack shipment carefully, and check contents against Packing List. Notify Roots if a shortage appears.
- Store in a clean, dry location until ready for installation. Lift by methods discussed under INSTALLATION to avoid straining or distorting the equipment. Keep covers on all openings. Protect against weather and corrosion if outdoor storage is necessary. See page 4 for instructions.
- Read OPERATING LIMITATIONS and INSTALLATION sections in this manual and plan the complete installation.
- Provide for adequate safeguards against accidents to persons working on or near the equipment during both installation and operation. See SAFETY PRECAUTIONS.
- Install all equipment correctly. Foundation design must be adequate and piping carefully done. Use recommended accessories for operating protection.
- Make sure both driving and driven equipment is correctly lubricated before start-up. See LUBRICATION.
- In event of trouble during installation or operation, do not attempt repairs of Roots furnished equipment. Notify Roots, giving all nameplate information plus an outline of operating conditions and a description of the trouble. Unauthorized attempts at equipment repair may void Roots warranty.
- Units out of warranty may be repaired or adjusted by the owner. Good inspection and maintenance practices should reduce the need for repairs.

NOTE: Information in this manual is correct as of the date of publication. Roots reserves the right to make design or material changes without notice, and without obligation to make similar changes on equipment of prior manufacture.

For your nearest Roots Office, dial our Customer Service Hot Line toll free: 1-877-363-ROOT(S) (7668) or direct 832-590-2600.

**Roots products are sold subject to the current General Terms of Sale, GTS-5001 and Warranty Policy WP-5020. Copies are available upon request.
Contact your local Roots Office or Roots Customer Service Hot Line 1-877-363-ROOT(S) (7668) or direct 281-966-4700.**

Safety Precautions

It is important that all personnel observe safety precautions to minimize the chances of injury. Among many considerations, the following should be particularly noted:

- Blower casing and associated piping or accessories may become hot enough to cause major skin burns on contact.
- Internal and external rotating parts of the blower and driving equipment can produce serious physical injuries. Do not reach into any opening in the blower while it is operating, or while subject to accidental starting. Protect external moving parts with adequate guards.
- Disconnect power before doing any work, and avoid bypassing or rendering inoperative any safety or protective devices.
- If blower is operated with piping disconnected, place a strong coarse screen over the inlet and avoid standing in the discharge air stream. **CAUTION: Never cover the blower inlet with your hand or other part of body.**
- Stay clear of inlet and discharge openings.
- Stay clear of the blast from pressure relief valves and the suction area of vacuum relief valves.
- Use proper care and good procedures in handling, lifting, installing, operating and maintaining the equipment.
- Casing pressure must not exceed 25 PSI (1725 mbar) gauge. Do not pressurize vented cavities from an external source, nor restrict the vents without first consulting Roots.
- Do not use air blowers on explosive or hazardous gases.
- Other potential hazards to safety may also be associated with operation of this equipment. All personnel working in or passing through the area should be trained to exercise adequate general safety precautions.

Operating Limitations

A ROOTS™ blower or exhauster must be operated within certain approved limiting conditions to enable continued satisfactory performance. Warranty is contingent on such operation.

Maximum limits for pressure, temperature and speed are specified in TABLE 3, page 12 in the RCS-J Section and TABLE 5, page 17 in the DVJ Section for various models & sizes of blowers & exhausters. These limits apply to all units of normal construction, when operated under standard atmospheric conditions. Be sure to arrange connections or taps for thermometers and pressure or vacuum gauges at or near the inlet and discharge connections of the unit. These, along with a good tachometer, will enable periodic checks of operating conditions.

PRESSURE – The pressure rise, between inlet and discharge, must not exceed the figure listed for the specific unit frame size concerned. Also, in any system where the unit inlet is at a positive pressure above atmosphere a maximum case rating of 25 PSI gauge (1725 mbar) should not be exceeded without first consulting ROOTS. Never should the maximum allowable differential pressure be exceeded.

On vacuum service, with the discharge to atmospheric pressure, the inlet suction or vacuum must not be greater than values listed for the specific frame size.

TEMPERATURE – Blower & exhauster frame sizes are approved only for installations where the following temperature limitations can be maintained in service:

- Measured temperature rise must not exceed listed values when the inlet is at ambient temperature. Ambient is considered as the general temperature of the space

around the unit. This is not outdoor temperature unless the unit is installed outdoors.

- If inlet temperature is higher than ambient, the listed allowable temperature rise values must be reduced by 2/3 of the difference between the actual measured inlet temperature and the ambient temperature.
- The average of the inlet and discharge temperature must not exceed 250°F. (121°C).
- The ambient temperature of the space the blower/motor is installed in should not be higher than 120°F (48.8°C).

SPEED – These blowers & exhausters may be operated at speeds up to the maximum listed for the various frame sizes. They may be direct coupled to suitable constant speed drivers if pressure/temperature conditions are also within limits. At low speeds, excessive temperature rise may be a limiting factor.

Special Note: The listed maximum allowable temperature rise for any particular blower & exhauster may occur well before its maximum pressure or vacuum rating is reached. This may occur at high altitude, low vacuum or at very low speed. The units' operating limit is always determined by the maximum rating reached first. It can be any one of the three: Pressure, Temperature or Speed.

Installation

ROOTS™ blowers & exhausters are treated after factory assembly to protect against normal atmospheric corrosion. The maximum period of internal protection is considered to be one year under average conditions, if shipping plugs & seals are not removed. Protection against chemical or salt water atmosphere is not provided. Avoid opening the unit until ready to start installation, as corrosion protection will be quickly lost due to evaporation.

If there is to be an extended period between installation and start up, the following steps should be taken to ensure corrosion protection. See “Cleaning & Preservation” page 18 for DVJ units.

- ❑ Coat internals of cylinder, gearbox and drive end bearing reservoir with Nox-Rust VCI-10 or equivalent. Repeat once a year or as conditions may require. Nox-Rust VCI-10 is petroleum soluble and does not have to be removed before lubricating. It may be obtained from Daubert Chemical Co., 2000 Spring Rd., Oak Brook, Ill. 60521.
- ❑ Paint shaft extension, inlet and discharge flanges, and all other exposed surfaces with Nox-Rust X-110 or equivalent.
- ❑ Seal inlet, discharge, and vent openings. It is not recommended that the unit be set in place, piped to the system, and allowed to remain idle for extended periods. If any part is left open to the atmosphere, the Nox-Rust VCI-10 vapor will escape and lose its effectiveness.
- ❑ Protect units from excessive vibration during storage.
- ❑ Rotate shaft three or four revolutions every two weeks.
- ❑ Prior to start up, remove flange covers on both inlet and discharge and inspect internals to insure absence of rust. Check all internal clearances. Also, at this time, remove gearbox and drive end bearing cover and inspect gear teeth and bearings for rust.

Because of the completely enclosed unit design, location of the installation is generally not a critical matter. A clean, dry and protected indoor location is preferred. However, an outdoor location will normally give satisfactory service. Important requirements are that the correct grade of lubricating oil be provided for expected operating temperatures, and that the unit be located so that routine checking and servicing can be performed conveniently. Proper care in locating driver and accessory equipment must also be considered.

Supervision of the installation by a Roots Service Engineer is not usually required for these units. Workmen with experience in installing light to medium weight machinery should be able to produce satisfactory results. Handling of the equipment needs to be accomplished with care, and in compliance with safe practices. Unit mounting must be solid, without strain or twist, and air piping must be clean, accurately aligned and properly connected.

Bare-shaft Units: Two methods are used to handle a unit without base. One is to use lifting lugs bolted into the top of the unit headplates. Test them first for tightness and fractures by tapping with a hammer. In lifting, keep the direction of

cable pull on these bolts as nearly vertical as possible. If lifting lugs are not available, lifting slings may be passed under the cylinder adjacent to the headplates. Either method prevents strain on the extended drive shaft.

Packaged Units: When the unit is furnished mounted on a baseplate, with or without a driver, use of lifting slings passing under the base flanges is required. Arrange these slings so that no strains are placed on the unit casing or mounting feet, or on any mounted accessory equipment. **DO NOT** use the lifting lugs in the top of the unit headplates.

Before starting the installation, remove plugs, covers or seals from unit inlet and discharge connections and inspect the interior completely for foreign material. If cleaning is required, finish by washing the cylinder, headplates and impeller thoroughly with an approved solvent. Turn the drive shaft by hand to make sure that the impellers turn freely at all points. Anti-rust compound on the connection flanges and drive shaft extension may also be removed at this time with the same solvent. Cover the flanges until ready to connect piping.

Mounting

Care will pay dividends when arranging the unit mounting. This is especially true when the unit is a “bare-shaft” unit furnished without a baseplate. The convenient procedure may be to mount such a unit directly on a floor or small concrete pad, but this generally produces the least satisfactory results. It definitely causes the most problems in leveling and alignment and may result in a “Soft Foot” condition. Correct soft foot before operation to avoid unnecessary loading on the casing and bearings. Direct use of building structural framing members is not recommended.

For blowers without a base, a well anchored and carefully leveled steel or cast iron mounting plate is recommended. The plate should be at least 1 inch (25 mm) thick, with its top surface machined flat, and large enough to provide leveling areas at one side and one end after the unit is mounted. It should have properly sized studs or tapped holes located to match the unit foot drilling. Proper use of a high quality machinist’s level is necessary for adequate installation.

With the mounting plate in place and leveled, set the unit on it without bolting and check for rocking. If it is not solid, determine the total thickness of shims required under one foot to stop rocking. Place half of this under each of the diagonally-opposite short feet, and tighten the mounting studs or screws. Rotate the drive shaft to make sure the impellers turn freely. If the unit is to be direct coupled to a driving motor, consider the height of the motor shaft and the necessity for it to be aligned very accurately with the unit shaft. Best unit arrangement is directly bolted to the mounting plate while the driver is on shims of at least 1/8 inch (3mm) thickness. This allows adjustment of motor position in final shaft alignment by varying the shim thickness.

Aligning

When unit and driver are factory mounted on a common baseplate, the assembly will have been properly aligned and is to be treated as a unit for leveling purposes. Satisfactory

installation can be obtained by setting the baseplate on a concrete slab that is rigid and free of vibration, and leveling the top of the base carefully in two directions so that it is free of twist. The slab must be provided with suitable anchor bolts. The use of grouting under and partly inside the leveled and shimmed base is recommended.

It is possible for a base-mounted assembly to become twisted during shipment, thus disturbing the original alignment. For this reason, make the following checks after the base has been leveled and bolted down. Disconnect the drive and rotate the unit shaft by hand. It should turn freely at all points. Loosen the unit foot hold-down screws and determine whether all feet are evenly in contact with the base. If not, insert shims as required and again check for free impeller rotation. Finally, if unit is direct coupled to the driver, check shaft and coupling alignment carefully and make any necessary corrections.

In planning the installation, and before setting the unit, consider how piping arrangements are dictated by the unit design and assembly. Drive shaft rotation must be established accordingly and is indicated by an arrow near the shaft.

Typical arrangement on vertical units has the drive shaft at the top with counterclockwise rotation and discharge to the left. Horizontal units are typically arranged with the drive shaft at the left with counterclockwise rotation and discharge down. See drawings on pages 14-16 for 700 Series RCS-J and pages 21-23 for 700 Series DVJ, for other various unit arrangements and possible conversions.

When a unit is DIRECT COUPLED to its driver, the driver RPM must be selected or governed so as not to exceed the maximum speed rating of the unit. Refer to TABLE 3, page 12 in the RCS-J Section and TABLE 5, page 17 in the DVJ Section, for allowable speeds of various unit sizes.

A flexible type coupling should always be used to connect the driver and unit shafts.

When direct coupling a motor or engine to a blower you must ensure there is sufficient gap between the coupling halves and the element to prevent thrust loading the blower bearings. When a motor, engine or blower is operated the shafts may expand axially. If the coupling is installed in such a manner that there is not enough room for expansion the blower shaft can be forced back into the blower and cause the impeller to contact the gear end headplate resulting in damage to the blower. The two shafts must be in as near perfect alignment in all directions as possible, and the gap must be established with the motor armature on its electrical center if end-play exists.

The following requirements of a good installation are recommended. When selecting a coupling to be fitted to the blower shaft Roots recommends a taper lock style coupling to ensure proper contact with the blower shaft. Coupling halves must be fitted to the two shafts with a line to line thru .001" interference fit. Coupling halves must be warmed up per coupling manufacturer's recommendations. Maximum deviation in offset alignment of the shafts should not exceed .005" (.13 mm) total indicator reading, taken on the two coupling hubs. Maximum deviation from parallel of the inside coupling faces should not exceed .001" (.03 mm) when checked at six points around the coupling.

The two shafts must be in as near perfect alignment in all directions as possible, and the gap must be established with the motor armature on its electrical center if end-play exists. Coupling manufacturer's recommendations for maximum misalignment, although acceptable for the coupling are normally too large to achieve smooth operation and maximum life of the blower.

When a unit is BELT DRIVEN, the proper selection of sheave diameters will result in the required unit speed. When selecting a sheave to be fitted to the blower shaft ROOTS recommends a taper lock style sheave to insure proper contact with the blower shaft. This flexibility can lead to operating temperature problems caused by unit speed being too low. Make sure the drive speed selected is within the allowable range for the specific unit size, as specified under TABLE 3, page 12 in the RCS-J Section and TABLE 5, page 17 in the DVJ Section.

Belt drive arrangements should employ two or more 5V, or 8V matched set of banded belts running in grooved sheaves. Installation of the driver is less critical than for direct coupling, but

Allowable Overhung Loads for V-belt Drives 700 Series RCS-J & DVJ Blowers

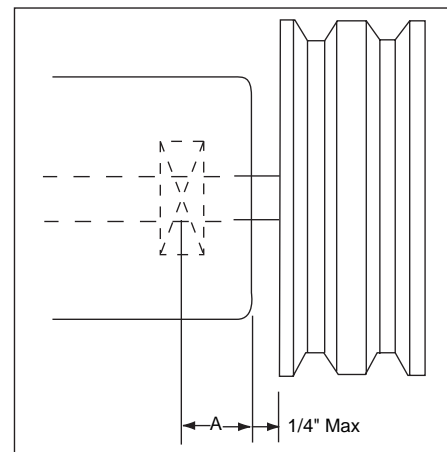

$$\text{Belt Pull lbs} = \frac{27500 \cdot \text{Motor HP}}{\text{Blower} \cdot \text{Sheave Diameter}}$$

$$\text{Shaft load (lb.in)} = \text{Belt Pull} \cdot \left(A + \frac{1}{4} + \frac{\text{Sheave Width}}{2} \right)$$

Gear Diameter	Dimension "A"		Max Allowable Shaft Load (lb-in.)	Min Sheave Diameter	Max Sheave Diameter
	Standard Unit	Bottom Drive or Double Shaft Seal			
7.00"	2.44	2.44	10,900	11.80"	4.43"

NOTE: Arc of sheave belt contact on the smaller sheave not to be less than 170°. Driver to be installed on the inlet side for vertical units.

Roots recommends the use of 5V or 8V matched set banded belts.

its shaft must be level and parallel with the unit shaft. The driver should be mounted on the inlet side of a vertical unit (horizontal piping). The driver must also be mounted on an adjustable base to permit installing, adjusting and removing the V-belts. To position the driver correctly, both sheaves need to be mounted on their shafts and the nominal shaft center distance known for the belt lengths to be used.

Acceptable Blower Drive Arrangement Options

Acceptable

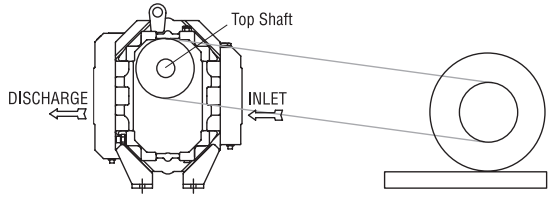

Motor On Inlet Side of Blower (Top Shaft)

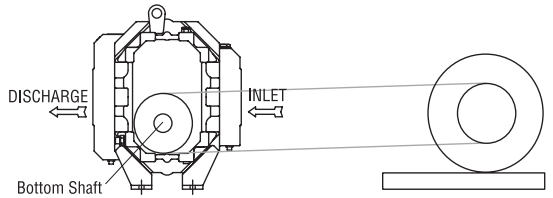

Motor On Inlet Side of Blower (Bottom Shaft)

Unacceptable

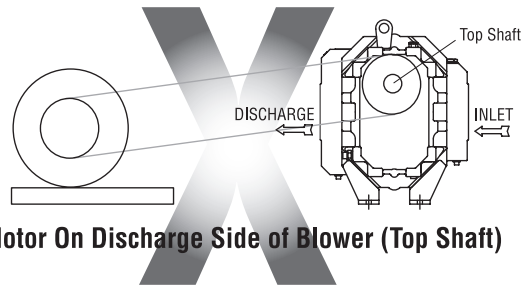

Motor On Discharge Side of Blower (Top Shaft)

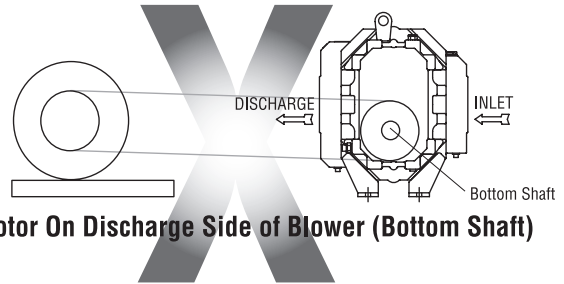

Motor On Discharge Side of Blower (Bottom Shaft)

CAUTION: Drive couplings and sheaves (pulleys) should have an interference fit to the shaft of the blower (set screw types of attachment generally do not provide reliable service.) It is recommended that the drive coupling or sheave used have a taper lock style bushing which is properly sized to provide the correct interference fit required. Drive couplings, that require heating to fit on the blower shaft, should be installed per coupling manufacturer recommendations. A drive coupling or sheave should not be forced on to the shaft of the blower as this could affect internal clearances resulting in damage to the blower.

Engine drive applications often require special consideration to drive coupling selection to avoid harmful torsional vibrations. These vibrations may lead to blower damage if not dampened adequately. It is often necessary to install a fly-wheel and/or a torsionally soft elastic element coupling based on the Engine manufacturer recommendations.

The driver sheave should also be mounted as close to its bearing as possible, and again should fit the shaft correctly. Position the driver on its adjustable base so that 2/3 of the total movement is available in the direction away from the unit, and mount the assembly so that the face of the sheave is accurately in line with the unit sheave. This position minimizes belt wear, and allows sufficient adjustment for both installing and tightening the belts. After belts are installed, adjust their tension in accordance with the manufacturer's instructions. However, only enough tension should be applied to prevent slippage when the unit is operating under load. Excessive tightening can lead to early bearing failures or shaft breakage.

Before operating the drive under power to check initial belt tension, first remove covers from the unit connections. Make sure the interior is still clean, then rotate the shaft by hand. Place a coarse screen over the inlet connection to prevent

anything being drawn into the unit while it is operating, and avoid standing in line with the discharge opening. Put oil in the sumps per instructions under **LUBRICATION**.

Piping

Before connecting piping, remove any remaining anti-rust compound from Unit connections. Clean pipe should be no smaller than unit connections. In addition, make sure it is free of scale, cuttings, weld beads, or foreign material of any kind. To further guard against damage to the unit, especially when an inlet filter is not used, install a substantial screen of 16 mesh backed with hardware cloth at or near the inlet connections. Make provisions to clean this screen of collected debris after a few hours of operation. It should be removed when its usefulness has ended, as the wire will eventually deteriorate and small pieces going into the unit may cause serious damage.

Pipe flanges or male threads must meet the unit connections accurately and squarely. DO NOT attempt to correct misalignment by springing or cramping the pipe. In most cases this will distort the unit casing and cause impeller rubbing. In severe cases it can prevent operation or result in a broken drive shaft. For similar reasons, piping should be supported near the unit to eliminate dead weight strains. Also, if pipe expansion is likely to occur from temperature change, installation of flexible connectors or expansion joints is advisable.

Figure 1, page 12 in the RCS-J Section, represents an installation with all accessory items that might be required under various operating conditions. Inlet piping should be completely free of valves or other restrictions. When a shut-off valve can not be avoided, make sure a full size vacuum relief is installed nearest the unit inlet. This will protect against unit overload caused by accidental closing of the shut-off valve.

Need for an inlet silencer will depend on unit speed and pressure, as well as sound-level requirements in the general

surroundings. An inlet filter is recommended, especially in dusty or sandy locations. A discharge silencer is also normally suggested, even though Whispair units operate at generally lower noise levels than conventional rotary blowers. Specific recommendations on silencing can be obtained from Roots.

Discharge piping requires a pressure relief valve, and should include a manual unloading valve to permit starting the unit under no-load conditions. Reliable pressure/vacuum gauges and good thermometers at both inlet and discharge are recommended to allow making the important checks on unit operating conditions. The back-pressure regulator shown in Figure 1, page 12 in the RCS-J Section, is useful mainly when volume demands vary while the unit operates at constant output. If demand is constant, but somewhat lower than the unit output, excess may be blown off through the manual unloading valve.

In multiple unit installations where two or more units operate with a common header, use of check valves is mandatory. These should be of a direct acting or free swinging type, with one valve located in each line between the unit and header. Properly installed, they will protect against damage from reverse rotation caused by air and material back-flow through an idle unit.

After piping is completed, and before applying power, rotate the drive shaft by hand again. If it does not move with uniform freedom, look for uneven mounting, piping strain, excessive belt tension or coupling misalignment.

DO NOT operate the unit at this time unless it has been lubricated per instructions.

Lubrication

Due to sludge build-up and seal leakage problems, Roots recommendation is DO NOT USE Mobil SHC synthetic oils in Roots blowers.

LUBRICATION: For Units with Splash Lubrication on Both Ends.

- The specified and recommended oil is ROOTS® Synthetic oil of correct viscosity per Table 1, this page.
- The proper oil level should be half way or middle of the sight gauge when the blower is not operating. **DO NOT OVERFILL OIL SUMP/S** as damage to the blower may occur.
- Oil level may rise or fall in the gauge during operation to an extent depending somewhat on oil temperature and blower speed.
- It is recommended that the oil be changed after initial 100 hours of operation.
- Proper service intervals of the oil thereafter are based on the discharge air temperature of the blower. Please refer to the information below to properly determine the oil service intervals.
- If you choose to use another oil other than the specified and recommended ROOTS® Synthetic, use a good grade of industrial type non-detergent, rust inhibiting, anti-foaming oil and of correct viscosity per Table 1, this page.
- Roots does **NOT** recommend the use of automotive type lubricants, as they are not formulated with the properties mentioned above.

Normal life expectancy of the specified and recommended ROOTS® Synthetic oil is approximately 6000 hours with an oil temperature of 180°F (82°C) or less. As the oil temperature increases by increments of 15°F (8°C), the oil life is reduced by half for each 15°F (8°C) increase. Example: Oil temperatures of 195°F (90.5°C) will produce a life expectancy reduced by half or 3000 hours oil service life.

Normal life expectancy of petroleum based oils is about 2000 hours with an oil temperature of about 180°F (82°C). As the oil temperature increases by increments of 15°F (8°C), the life is reduced by half for each 15°F (8°C) increase. Example: Oil temperatures of 195°F (90.5°C) will produce life expectancy reduced by half or 1000 hours oil service life.

NOTE: To estimate oil temperature, multiply the discharge temperature of the blower by 0.88. Example: if the discharge air temperature of the blower is 200° F, it is estimated that the oil temperature is 160° F.

Table 1 - Recommended Oil Grades

Ambient* Temperature °F (°C)	ISO Viscosity No.
Above 90° (32°)	320
32° to 90° (0° to 32°)	220
0° to 32° (-18° to 0°)	150
Below 0° (-18°)	100

*Ambient temperature is defined as the temperature of the space in which the blower and drive are located.

High ambient temperatures contribute to increased lubrication sump temperatures. In situations such as blowers in an enclosure, blowers exposed to radiant heat from other sources, blowers installed in areas with poor air circulation or ambient temperatures above 80°F the lubrication sump temperature should be measured rather than fully rely on the calculation.

Bearings and oil seals are lubricated by the action of the timing gears or oil slingers which dip into the main oil sumps causing oil to splash directly on gears and into bearings and seals. A drain port is provided below each bearing to prevent an excessive amount of oil in the bearings. Seals located inboard of the bearings in each headplate effectively retain oil within the sumps. Any small leakage that may occur should the seals wear passes into a cavity in each vented headplate and is drained downward. Oil sumps on each end of the blower are filled by removing top vent plugs, Item (21), and filling until oil reaches the middle of the oil level sight gauge, Item (37).

Initial filling of the sumps should be accomplished with the blower not operating, in order to obtain the correct oil level. Approximate oil quantities required for blowers of the various models and configurations are listed in Table 2, this page.

The oil level should not fall below the middle of the site gauge when the blower is idle.

Proper lubrication is usually the most important single consideration in obtaining maximum service life and satisfactory operation from the unit. Unless operating conditions are severe, a weekly check of oil level and necessary addition of lubricant should be sufficient. During the first week of operation, check the oil levels in the oil sumps about once a day, and watch for leaks. Replenish as necessary. Thereafter, an occasional check should be sufficient.

More frequent oil service may be necessary if the blower is operated in a very dusty location.

*ROOTS® Synthetic oil is superior in performance to petroleum based products. It has high oxidation stability, excellent corrosion protection, extremely high film strength and low coefficient of friction. Typical oil change intervals are increased 2-3 times over petroleum based lubricants. Also, ROOTS® Synthetic oil is 100% compatible with petroleum based oils. Simply drain the oil in the blower and refill the reservoirs with ROOTS® Synthetic oil to maintain optimum performance of your ROOTS™ blower.

Table 2 - 700 Series RCS-J/RCS-DVJ Approximate Oil Sump Capacities

Model No./ Drive Shaft Location	Gear Box		Drive End	
	Fl. Oz.	Liters	Fl. Oz.	Liters
700 RCS-J/ RCS-DVJ (left or right)	155	4.59	70	2.07
700 RCS-J/ RCS-DVJ (top or bottom)	80	2.37	40	1.18

These capacities are provided to assist stocking the correct amount of oil. Exact sump capacity may differ slightly. Review the proper filling instructions as detailed above.

Operation

Before operating a blower under power for the first time, recheck the unit and the installation thoroughly to reduce the likelihood of avoidable troubles. Use the following procedure check list as a guide, but consider any other special conditions in the installation.

1. Be certain that no bolts, tools, rags, or debris have been left in the blower air chamber or piping.
2. If an outdoor intake without filter is used, be sure the opening is located so it cannot pick up dirt and is protected by a strong screen or grille. Use of the temporary protective screen as described under INSTALLATION is strongly recommended.
3. Recheck blower leveling, drive alignment and tightness of all mounting bolts if installation is not recent. If belt drive is used, adjust belt tension correctly.
4. Turn drive shaft by hand to make sure impellers still rotate without bumping or rubbing at any point.
5. Ensure oil levels in the main oil sumps are correct.
6. Check lubrication of driver. If it is an electric motor, be sure that power is available and that electrical overload devices are installed and workable.
7. Open the manual unloading valve in the discharge air line. If a valve is in the inlet piping, be sure it is open.
8. Bump blower a few revolutions with driver to check that direction of rotation agrees with arrow near blower shaft, and that both coast freely to a stop.

After the preceding points are cleared, blower is ready for trial operation under “no-load” conditions. The following procedure is suggested to cover this initial operation test period.

- a. Start blower, let it accelerate to full speed, then shut off. Listen for knocking sounds, both with power on and as speed slows down.
- b. After blower comes to a complete stop, repeat above, but let blower run 2 or 3 minutes. Check for noises, such as knocking sounds.
- c. After blower comes to a complete stop, operate blower for about 10 minutes unloaded. Check oil levels. Observe cylinder and headplate surfaces for development of hot spots such as burned paint, indicating impeller rubs. Be aware of any noticeable increase in vibration.

Assuming that all trials have been satisfactory, or that necessary corrections have been made, the blower should now have a final check run of at least one hour under normal operating conditions. After blower is restarted, gradually close the discharge unloading valve to apply working pressure. At this point it is recommended that a good pressure gauge or manometer be connected into the discharge line if not already provided, and that thermometers be in both inlet and discharge lines. Readings from these instruments will show whether pressure or temperature ratings of the blower are being exceeded.

During the final run, check operating conditions frequently and observe the oil levels at reasonable intervals. If excessive noise or local heating develops, shut down immediately and determine the cause. If either pressure rise or temperature rise across the blower exceeds the limit specified in this manual, shut down and investigate conditions in the piping system. Refer to the **TROUBLESHOOTING CHECKLIST** for suggestions on various problems that may appear.

The blower should now be ready for continuous duty operation at full load. During the first few days make periodic checks to determine whether all conditions remain steady, or at least acceptable. This may be particularly important if the blower is supplying air to a process system where conditions can vary. At the first opportunity, stop the blower and clean the temporary inlet protective screen. If no appreciable amount of debris has collected, the screen may be removed. See comments under **INSTALLATION**. At this same time, verify leveling, coupling alignment or belt tension, and mounting bolt tightness.

Should operating experience prove that blower capacity is a little too high for the actual air requirements, a small excess may be blown off continuously through the manual unloading or vent valve. Never rely on the pressure relief valve as an automatic vent. Such use may cause the discharge pressure to become excessive, and can also result in unsafe operation of the valve itself. If blower capacity appears to be too low, refer to the **TROUBLESHOOTING CHECKLIST**. See 700 Series DVJ section, page 17 for additional operation information.

Vibration Assessment Criteria

With measurements taken at the bearing locations on the housings, see chart below for an appropriate assessment guide for rotary lobe blowers rigidly mounted on stiff foundations.

In general, blower vibration levels should be monitored on a regular basis and the vibration trend observed for progressive or sudden change in level. If such a change occurs, the cause should be determined through spectral analysis.

As shown on the chart below, the level of all pass vibration will determine the need to measure discrete frequency vibration levels and the action required.

All Pass Vibration (in/sec)	Discrete Frequency Vibration (in/sec)	Action
0.45 or less	N/R	Acceptable
Greater than 0.45 but 1.0 or less	0.45 or less @ any frequency	Acceptable
	Greater than 0.45 @ any frequency	Investigate
Greater than 1.0	Less than 1.0	Investigate
	Greater than 1.0	Investigate

Troubleshooting Checklist

Trouble	Item	Possible Cause	Remedy
No flow	1	Speed too low	Check by tachometer and compare with published performance.
	2	Wrong rotation	Compare actual rotation with Figure 1, change driver if wrong.
	3	Obstruction in piping	Check piping, valves, silencer to assure open flow path.
Low capacity	4	Speed too low	See item 1, if belt drive, check for slippage and readjust tension.
	5	Excessive pressure rise	Check inlet vacuum and discharge pressure and compare with published performance.
	6	Obstruction in piping	See item 3.
	7	Excessive slip	Check inside of casing for worn or eroded surfaces causing excessive clearances
Excessive power	8	Speed too high	Check speed and compare with published performance.
	9	Excessive pressure rise	See item 5
	10	Impeller rubbing	Inspect outside of cylinder for high temperature areas, then check for impeller contact at these points. Correct blower mounting, drive alignment.
	11	Scale, sludge, rust or product build up	Clean blower appropriately
Damage to bearings or gears	12	Inadequate lubrication	Check oil sump levels in gear and drive end headplates
	13	Excessive lubrication	Check oil levels. If incorrect, drain and refill with clean oil of recommended grade.
	14	Excessive pressure rise	See item 5.
	15	Coupling misalignment	Check carefully. Realign if questionable.
	16	Excessive belt tension	Readjust for correct tension.
Vibration	17	Misalignment	See item 15
	18	Impellers rubbing	See item 10
	19	Worn bearings/gears	Check gear backlash and conditions of bearings and replace as indicated.
	20	Unbalanced or rubbing impeller	Scale or process material may build up on casing and impellers, or inside impellers. Remove build-up to restore original clearances and impeller balance.
	21	Driver or blower loose	Tighten mounting bolts securely.
	22	Piping resonances	Determine whether standing wave pressure pulsations are present in the piping.
	23	Scale/sludge build-ups	Clean out interior of impeller lobes to restore dynamic balance.
	24	Casing strain	Re-work piping alignment to remove excess strain.
Driver stops, or will not start	25	Impeller stuck	Check for excessive hot spot on headplate or cylinder. See item 10. Look for defective shaft bearing and/or gear teeth.
	26	Scale, sludge, rust or product build-up	Clean blower appropriately
Excessive breather	27	Broken seal	Replace seals
Blow-by or excessive oil leakage to vent area	28	Defective O-ring	Replace seals and O-ring
Excessive oil leakage in vent area	29	Defective/plugged breather	Replace breather and monitor oil leakage
	30	Oil level too high	Check sump levels in gear and drive headplates
	31	Oil type or viscosity incorrect	Check oil to ensure it meets recommendations. Drain then fill with clean oil of recommended grade.
	32	Blower running hot	Check blower operating conditions to ensure they are within the operating limitations defined in this manual.

Inspection & Maintenance: 700 Series RCS-J & DVJ Blowers

A good program of consistent inspection and maintenance is the most reliable method of minimizing repairs to a blower. A simple record of services and dates will help keep this work on a regular schedule. Basic service needs are:

- Lubrication
- Checking for hot spots
- Checking for increases or changes in vibration and noise
- Recording of operating pressures and temperatures

Above all, a blower must be operated within its specified rating limits, to obtain satisfactory service life.

A newly installed blower should be checked often during the first month of full-time operation. Attention there after may be less frequent assuming satisfactory performance. Lubrication is normally the most important consideration and weekly checks of lubricant levels in the gearbox and bearing reservoirs should be customary. Complete oil change schedules are discussed under **LUBRICATION**.

Driver lubrication practices should be in accordance with the manufacturer's instructions. If direct connected to the blower through a lubricated type coupling, the coupling should be checked and greased each time blower oil is changed. This will help reduce wear and prevent unnecessary vibration. In a belted drive system, check belt tension periodically and inspect for frayed or cracked belts.

In a new, and properly installed, unit there is no contact between the two impellers, or between the impellers and cylinder or headplates. Wear is confined to the bearings (which support and locate the shafts) the oil seals, and the timing gears. All are lubricated and wear should be minimal if clean oil of the correct grade is always used. Seals are subject to deterioration and wear, and may require replacement at varying periods.

Piston ring seals (28) are designed to operate without rubbing contact, once temperature and thermal growth have stabilized. The stationary rings will rub the rotating sleeve (38) briefly as a result of temperature cycles that occur during the startup and shutdown of the unit. The sleeves are hardened and the rings are coated with dry lubricant that provides for temporary break in wear. Replace piston ring seals if they become excessively worn.

Shaft bearings are designed for optimum life under average conditions with proper lubrication and are critical to the service life of the blower. Gradual bearing wear may allow a shaft position to change slightly, until rubbing develops between impeller and casing. This will cause spot heating, which can be detected by observing these surfaces. Sudden bearing situations are usually more serious. Since the shaft and impeller are no longer supported and properly located, extensive general damage to the blower casing and gears is likely to occur.

Oil seals should be considered expendable items, to be replaced whenever drainage from the headplate vent cavity becomes excessive or when the blower is disassembled for any reason. Some oil seal leakage may occur since an oil film under the lip is required for proper operation. Periodically leaked oil should be wiped off from surfaces. Minor seal leakage should not be considered as indicating seal replacement.

Timing gear wear, when correct lubrication is maintained, should be negligible over a period of years. Gear teeth are cut to provide the correct amount of backlash, and gears correctly mounted on the shafts will accommodate a normal amount of tooth wear without permitting contact between lobes of the two impellers. However, too high an oil level will cause churning and excessive heating. This is indicated by unusually high temperature at the bottom of the gear housing. Consequent heating of the gears will result in loss of tooth-clearance, backlash and rapid wear of the gear teeth usually will develop. Continuation of this tooth wear will eventually produce impeller contacts (knocking), and from this point serious damage will be unavoidable if blower operation is continued. A similar situation can be produced suddenly by gear tooth fracture, which is usually brought on by sustained overloading or momentary shock loads.

Problems may also develop from causes other than internal parts damage. Operating clearances within a blower are only a few thousandths of an inch. This makes it possible for impeller interferences or casing rubs to result from shifts in the blower mounting, or from changes in piping support. If this type of trouble is experienced, and the blower is found to be clean, try removing mounting strains. Loosen blower mounting bolts and reset the leveling and drive alignment. Then tighten mounting again, and make sure that all piping meets blower connections accurately and squarely. Foreign materials sucked into the blower will also cause trouble, which can only be cured by disconnecting the piping and thoroughly cleaning the blower interior.

A wide range of causes & solutions for operating troubles are covered in the **TROUBLESHOOTING CHECKLIST**. The remedies suggested should be performed by qualified mechanics with a good background. Major repairs generally are to be considered beyond the scope of maintenance, and should be referred to Roots.

Warranty situations should not be repaired at all, unless specific approval has been obtained through a Sales Office or the factory before starting work. Unauthorized disassembly within the warranty period may void the warranty.

700 Series RCS-J Section

Table 3 - Maximum Allowable Operation Conditions - 700 Series RCS-J

Frame Size	Speed RPM	Temperature Rise		Pressure Rise		Inlet Vacuum	
		°F	°C	PSI	mbar	INHG	mbar
715	2600	230	128	16	111	15	50
721	2600	230	128	15	104	15	50

Figure 1 - 700 Series RCS-J Air Blower Installation with Accessories

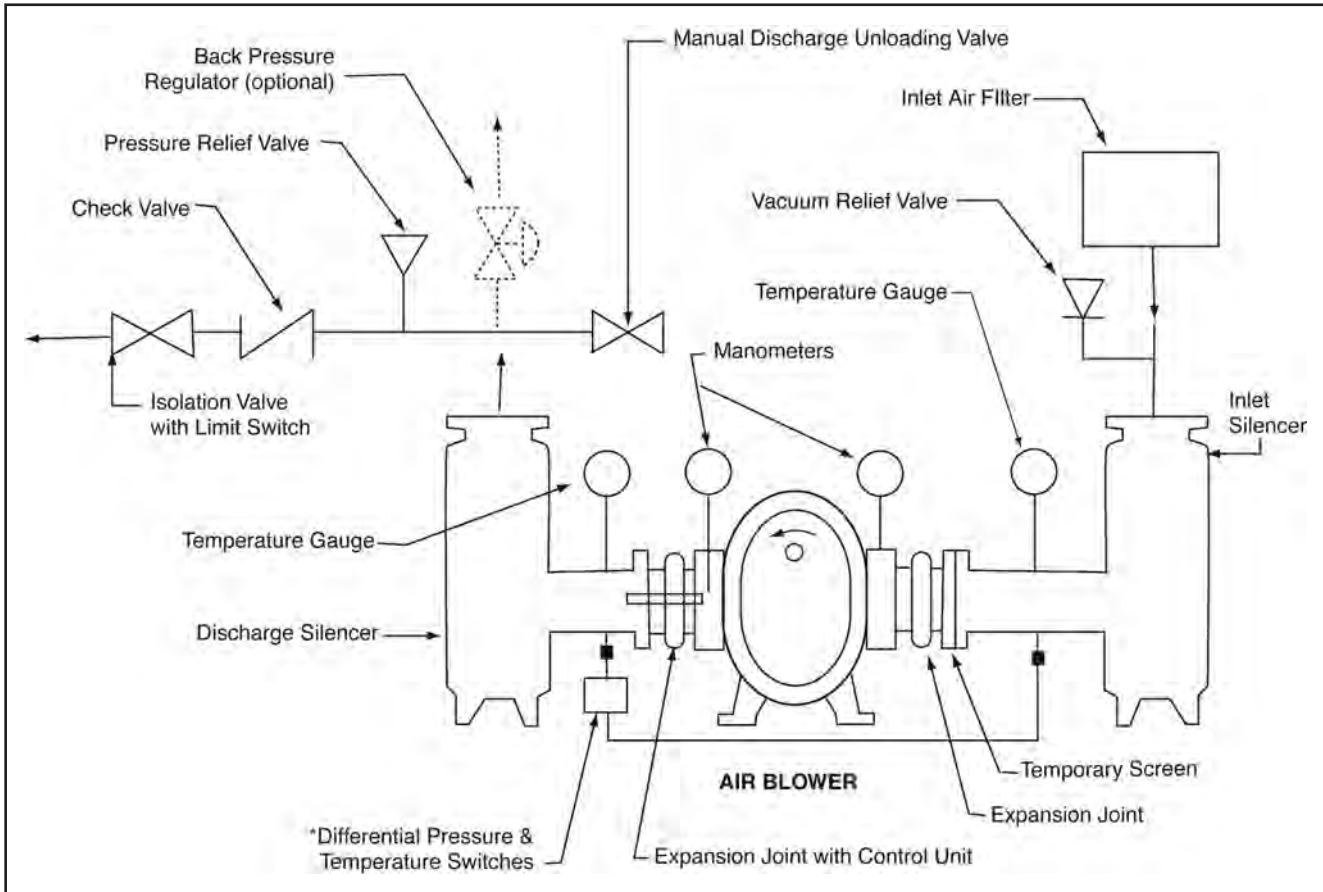

Above are suggested locations for available accessories.

Table 4 - Specified Lubricants

ROOTS® Synthetic Oil: ISO-VG-220 Grade	
	Part Number
Quart	813-106-001
Gallon	813-106-002
Case (12 qts)	813-106-008
ROOTS® Synthetic Oil: ISO-VG-320 Grade	
	Part Number
Quart	813-106-004
Gallon	813-106-005
Case (12 qts)	813-106-007

700 Series RCS-J Parts

Item Number	Part Name	Quantity
01	Headplate	2
03	Gearbox	1
04	Gear, Assembly	1
05	Drive End Cover	1
07	Gasket	2
09	Lubrication Label	2
10	Shim Set	1
11	Cylinder	1
12	Impeller & Shaft - Drive	1
13	Impeller & Shaft - Driven	1
14	Bearing Roller	4
16	Dowel Pin	4
17	Drive-Lok Pin	2
19	Key	1
20	Drive Screw	3
21	Plug - Vent	2
22	Drain - filler Plug	8
23	Cap Screw	36 (700)
27	Seal-Lip, Headplate	4
28	Seal-Ring	4
29	Washer, Wavy Spring	2
31	Locknuts	2
32	Capscrew	16
33	Seal, Lip	1
34	Clamp Plate - Drive End	2
35	Lock Washer	16
37	Oil Level Gauge	2
38	Sleeve - Piston Ring	4
40	Slinger - D.E (Top Drive)	1
40	Slinger - D.E. (Bottom Drive)	2
45	Pipe Plug	2
46	Slinger - G.E.	1
54	Clamp Plate - Gear End	2
55	Capscrew-butt. Hd	2
56	Washer	2
60	Capscrew	1
63	Lifting Lug	2
64	Pin, Spr (Top Drive)	1
65	Coupling	2
66	Nipple-pipe (700)	2
71	Scr, Set Soch CP (Bottom Drive)	1
73	Foot - R.H.	2
74	Foot - L.H.	2
78	Capscrew - Hex Hd.	2

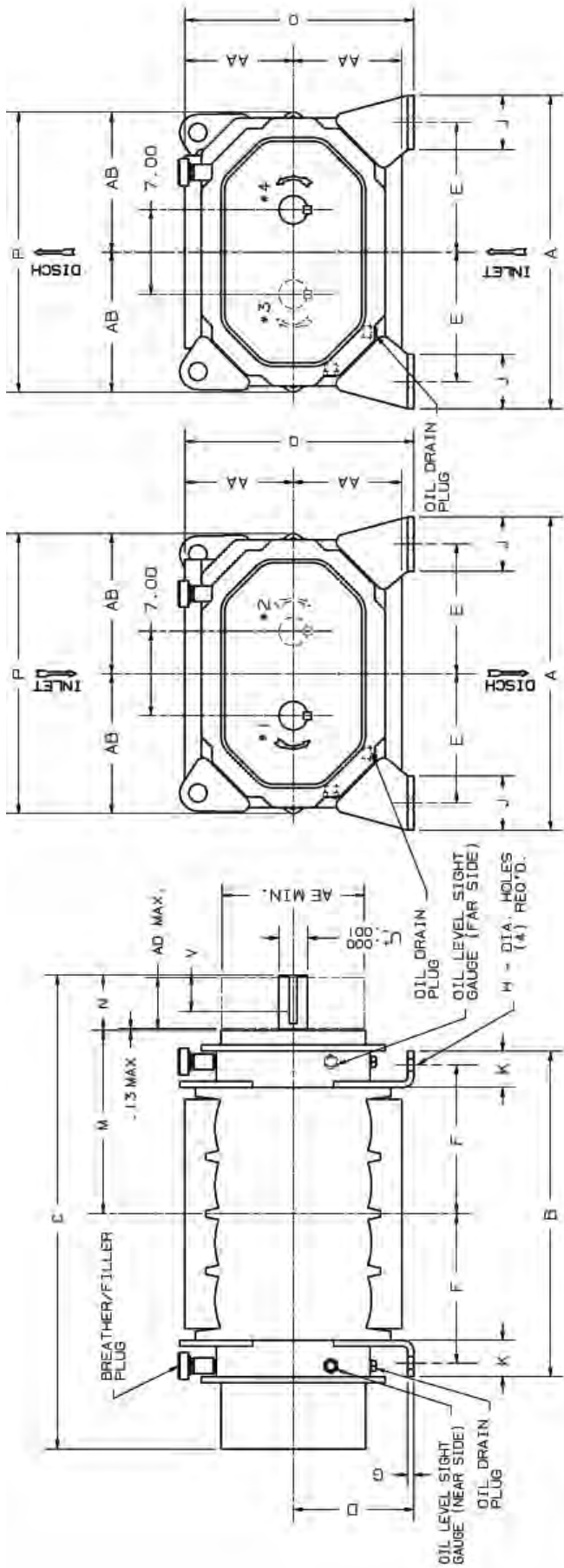

POSITION #1 FURNISHED UNLESS SPECIFIED OTHERWISE

ALTERNATE POSITIONS #2, #3 & #4 ALSO AVAILABLE

INLET AND DISCHARGE FLANGES TO MATE FLUSH AND SQUARE WITH FLAT FACE FLANGES ONLY. USE FULL FACE GASKETS FOR V-BELT DRIVEN UNITS MOTOR TO BE LOCATED ON DRIVE SHAFT SIDE OF BLOWER

700 RCS-JH BLOWER

FRAME SIZE	A	B	C	D	E	F	G	H	J	K	M	N	O	P	U	V	KEYWAY	W	W'	AA	AB	AD	AE	APPROX WEIGHT
715	26.00	21.50	33.88	10.00	10.75	9.63	.50	1.00	4.50	3.00	12.50	4.56	19.00	23.25	2	3.75	3.00	1.825x.313	10"FLG	9.00	11.63	4.43	11.80	11.00
721	"	27.00	39.38	"	"	12.38	"	"	"	"	15.25	"	"	"	"	"	"	12"FLG	10"FLG	"	"	"	"	1200

OPENING	8"FLG	10"FLG	12"FLG
BOLT CIRCLE	8.00	10.00	12.00
FLANGE O.D.	11.75	14.25	17.00
No. TAPPED HOLES	8	12	12
SIZE HOLES	3/4-10	7/8-9	7/8-9
TAP DEPTH	1.15	1.31	1.31

W - INLET
W' - DISCHARGE
AD - SHEAVE WIDTH
AE - SHEAVE DIAMETER
H

ALL DIMENSIONS IN INCHES



B- REVISED APPROX. WEIGHT JHB 10-21-93
A- REVISED PER ECN 3698-V RE 2/5/93

FR 2/5/93
DB
7089902 I
70899021

/PARTS I/XXAD

700 RCS - JH Blower

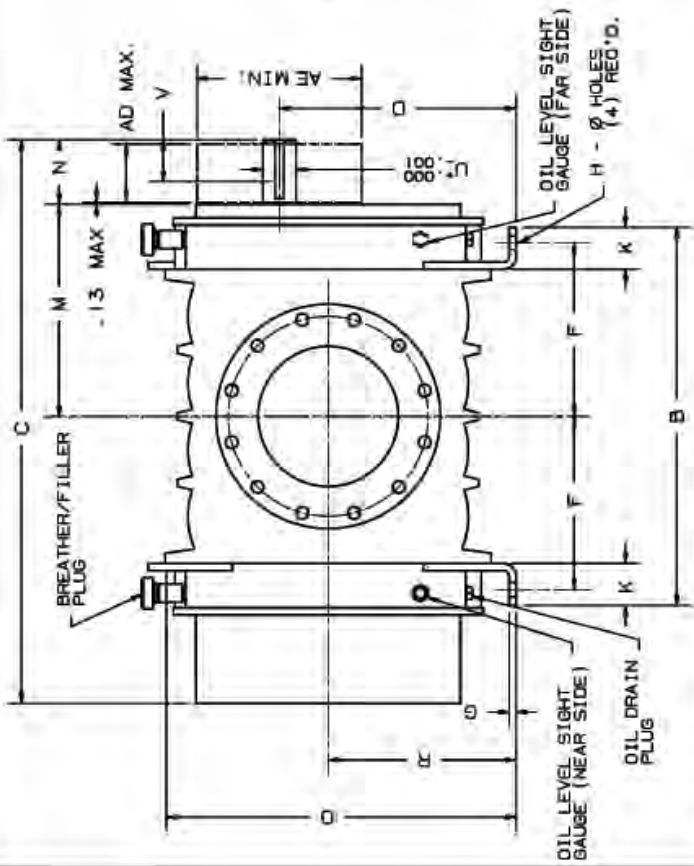

INLET AND DISCHARGE FLANGES TO MATE FLUSH AND SQUARE WITH FLAT FACE FLANGES ONLY. USE FULL FACE GASKETS FOR V-BELT DRIVEN UNITS MOTOR TO BE LOCATED ON INLET SIDE OF BLOWER

700 RCS-JV BLOWER

FRAME SIZE	A	B	C	D	E	F	G	H	J	K	M	N	O	P	R	U	V	KEYWAY	W	W'	AA	AD	AE	APPROX WEIGHT
715	19.00	21.50	33.88	17.00	7.25	8.63	.50	1.00	4.50	3.00	12.50	4.56	25.13	18.00	13.50	2.375	3.00	.625x.313	10"FLG	8"FLG	9.00	4.43	11.80	1100
721	"	27.00	39.38	"	12.38	"	"	"	"	"	15.25	"	"	"	"	"	"	"	12"FLG	10"FLG	"	"	"	1200

W - INLET
 W' - DISCHARGE
 AD - SHEAVE WIDTH
 AE - SHEAVE DIAMETER
 H

ALL DIMENSIONS IN INCHES

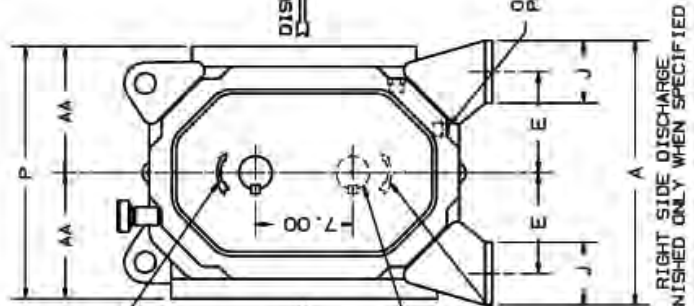

RIGHT SIDE DISCHARGE FURNISHED ONLY WHEN SPECIFIED

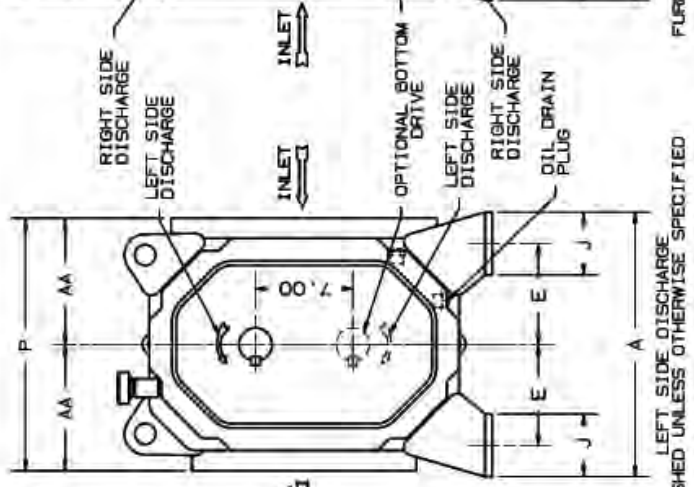

LEFT SIDE DISCHARGE FURNISHED UNLESS OTHERWISE SPECIFIED

CERTIFIED CORRECT FOR
 CUSTOMER ORDER No. _____
 ROOTS ORDER No. _____
 DATE _____

B-REVISED APPROX. WEIGHT JHB 10-21-93
 A-REVISED PER ECN 3698-V RVE 2/5/93

REVISE DATE BY CHKD APP

FR 1/7/91 DB CJKO APP

DRESSER ROOTS

DRESSER ROOTS
 CONSTRUCTION EQUIPMENT DIV. IN USA

70898021

PRINTED IN U.S.A.

700 RCS-JV Blower

700 Series DVJ Section

700 Series DVJ Blowers

Operating Limitations

The DVJ cannot be used in pressure applications as the pressure build-up discharges air outward through the cylinder slots with a result in high loss in blower efficiency and reduction in discharge flow.

Any unnecessary restrictions of discharge flow or atmospheric air inlet to the cylinder slots reduces the cooling air flow and limits blower operation, as the maximum temperature rise will occur below the normal limits of vacuum level.

Note: One cylinder slot plenum must have a full size inlet silencer with no valve or other restrictions. The other port must have the metal cover plate installed.

Installation

Do not install a V-belt driven DVJ Vacuum Blower with motor on the discharge side. The addition of belt forces in this plane could cause drive impeller rubs in the cylinder. A temporary cover is installed on one jet port and a permanent on the other at the factory. A silencer must be installed in place of the temporary cover before operating the blower, however, the permanent cover and silencer locations may be exchanged if the installation requires.

The permanent cover must be removed, both jet plenums inspected and cleared of foreign material, then the permanent cover and silencer installed in the desired locations before operating. Full size jet and discharge silencers are desirable, however, the jet silencer may be reduced one nominal size providing either the vacuum level is less than 18.5" Hg or the gear speed is below 3650 feet per minute. Both the jet silencer and the discharge silencer may be reduced one nominal size in applications with vacuum levels less than 18.5" Hg and a gear speed below 3650 feet per minute.

Jet and discharge flow restrictions result in increased blower temperature rise and should be checked as a possible cause if the temperature rise limits blower operation to less than the maximum vacuum level. Backpressure limits are shown in Table 6 on this page, DVJ Section. No valves should be used in the discharge piping.

Some type of protection, such as a filter or screen (1/4" mesh) is necessary to stop foreign particle entry through the jet port. Outside installations may also require some weather protection to prevent the entry of rain or snow. An elbow or some other pipe configuration is desirable to assist in keeping the screen clear of foreign particles and the direct entry of rain or snow.

Operation

All recheck points in this manual should be followed with the addition and/or supersedure of the following:

- (1, add.) Be certain no rags, bolts, or dirt have been left in the cylinder slot inlet plenums
- (7, add.) No valves should be installed in the discharge or jet silencer pipe

The blower is suitable for vacuum operation only. A water manometer should be used on the discharge plenum to determine that the maximum discharge pressure has not been exceeded.

Troubleshooting

All troubleshooting points in this manual should be followed with the addition/or supersedure of the following:

Excessive temperature rise - check for possible cylinder slot inlet flow restriction, excessive backpressure on the discharge, and troubleshooting checklist in this manual.

Table 5-Maximum Allowable Operation Conditions - 700 Series DVJ

Frame Size	Speed RPM	Temperature Rise		Inlet Vacuum	
		°F	°C	INHG	mbar
721	2600	260	145	27	684

Table 6-DVJ Section

Blower Discharge Back Pressure Limit

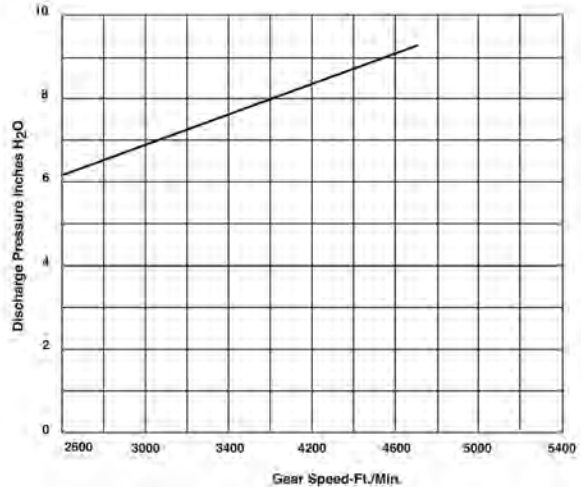

$$\text{Gear Speed} = 0.262 \times 7.0 \times \text{RPM}$$

Figure 2 - 700 Series DVJ Air Blower Installation with Accessories

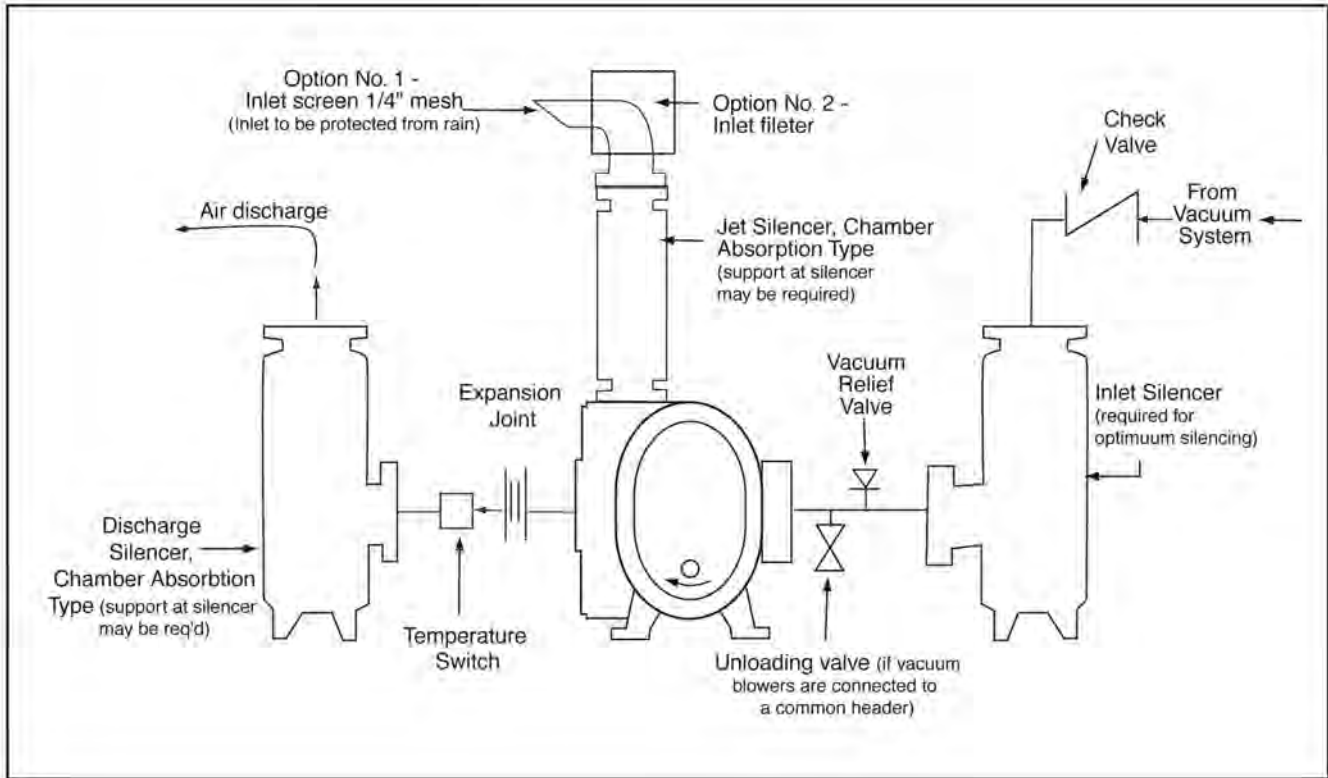

721 DVJ Blowers are Supplied with Internal Abradable Graphite-Based Coating

Coating

The coating is basically a fine-grained natural graphite*. It is applied as several coats. Coating applied after the machine's internal clearances and impeller timing are established. The effect of coating is to close up internal clearances, decreasing slip and increasing flow and efficiency at any given speed. Exhaust air may carry some coating particles.

Characteristics of Machines with Coated Internal Service

Machines with internal abradable coating are for use with clean, dry air only.

After coating, it is not practical to try to measure clearances involving these surfaces before or after running the machine. After coating and before running, some coated surfaces may even be touching. After running, the coated surfaces may have abraded areas and scratches, due to run-in contact between the surfaces.

Do not attempt to measure clearances involving coated surfaces as a basis for setting impellers in relation to the cylinder bore, headplates, or each other (fronts and backs). Clearance settings can be made accurately only with uncoated parts.

Cleaning and Preservation

Where internal, inspection indicates a need for cleaning coated surfaces of dirt, dust, etc., wipe clean only with a clean, dry

rag. Do not use a solvent or cleaner of any kind or allow a solvent or cleaner to reach these surfaces while cleaning uncoated surfaces.

If internal protection from rust or corrosion is required due, for example, to removal of the machine from service, or if the internal protections furnished as shipped by the factory has been removed, do not use a liquid preservative of any kind on these coated surfaces. Bags of vapor inhibitor powder, such as Shell Oil Company VPI No. 250 may be used internally, with all machine openings sealed with vapor barrier paper or tape.

Trouble Shooting Check List

This list in standard instructions applies, except note that in those lists and in various locations throughout the standard instruction manuals for uncoated machines, rubbing, knocking, contact and wear between internal surfaces are mentioned as trouble indicators. This is with respect to metal-to-metal interference. Coated surfaces can have very close clearances and will wear in, or abrade, between surfaces, showing rub or scratch marks which are normal conditions. These can usually be differentiated from metal-to-metal contact.

Cleaning, Coating & Curing Procedures for Applying Abradable Coating

General. These procedures are for coating new uncoated repair parts, spot repair of coating, or renewal. If setting

***Abradable coating applied to impellers is Slip Plate #3 as manufactured by Superior Graphite Co. For a material safety data sheet, go to www.slipplate.com. Study material safety data sheet before working with Slip Plate #3.**

clearances and timing are involved, this should be done before the new parts are coated. Subsequent cleaning and coating may involve at least partial disassembly for proper cleaning without damaging the coating of other original parts still coated, and to apply coating properly.

Normally, for new uncoated surfaces, three coats are applied and each coat must be properly cured.

Cleaning Before Coating

For new uncoated surfaces, apply the cleaner with a clean, "soaked" rag. Apply the cleaner liberally, allow to set for one to two minutes, then wipe off. Repeat if necessary. Avoid cleaning surfaces which will not be coated.

Wiping off with a clean, dry rag is the only cleaning allowable for spot repair or renewal of existing coating except in the case of a small area of grease or similar substance where scraping clean before reaching bare metal may be attempted. If too dirty to clean by these methods, disassembly will be required to remove the coating entirely, solvent clean, and recoat.

Preparation of Coating Material

The graphite suspended in the material settles out in a fairly short time and the can must be shaken well, and also frequently, during spray application. Generally, the initial shaking should continue until the ball in the can rattles freely and should then continue for at least five minutes more.

Coating General

Procedures for application are for one coat, but when multiple coats are to be applied, EACH coat must be completely cured per CURE procedure described following, before applying the next coat.

Coating Application

See notes on can concerning ventilation and inflammability.

Each layer of coating should be applied as evenly as possible. Note directions on the curing of each coating layer applied before applying subsequent coats.

The best distance of spray can nozzle to surface being coated is 8" to 12". Try to maintain this distance wherever space conditions allow it.

Coating Cure

This procedure is for EACH coat. When multiple coats are to be applied, this curing procedure must be used on EACH coat before the next coat is applied. Keep coated parts clean during curing.

Note that coated parts may feel dry or "tack free" after a few minutes, but the coat will not have the CURE that is required.

Curing Procedures

Alternate #1

Let set for 1-1/2 hours, minimum, at normal room temperature (not less than 70°F).

Alternate #2

Where ambient, and coated metal temperatures, are not at least 70°F, allow each coat to cure at least overnight in shop ambient (not warehouse or outdoors).

Alternate #3

Cure in oven, or by other source of even heat (not flame), for 10 minutes, minimum, at a temperature of 310°F ±10.

Alternate #4

Cure in oven, or by other source of even heat (not flame), for one-half hour, minimum, at a temperature of 200°F ±10°.

Check for Rotation

Finish blower buildup if not completely assembled when coated. In some instances, it is possible that clearances will be closed by coating to the extent that some surfaces touch. This is all right because the coating will wear (abrade) off as required. However, the blower may be hard to turn initially as a result. Turn over by hand until the running is free. Do not try to free up the blower by coupled or belted drive, and do not try to spin the rotors with shop air. Do not attempt to use any kind of solvent or cleaner to partially remove, coating – as this could ruin all of the coating. If necessary, coating can be scraped for such partial removal.

Complete Removal of Coating

This is for complete removal (to bare metal) of coating and may require some blower disassembly (depending on blower size and accessibility) for access to the coated parts and any overspray. Apply removal fluid liberally with a clean, "soaked" rag. Vigorously rubbing with this rag and scraping of the softened coating is required to clean surfaces down to bare metal, the amount of effort required will vary, depending upon the solvent used. Some are more effective than others. Protect surfaces, not coated, from rust.

Specified Lubricants

ROOTS® Synthetic Oil: ISO-VG-220 Grade	
	Part Number
Quart	813-106-001
Gallon	813-106-002
Case (12 qts)	813-106-008
ROOTS® Synthetic Oil: ISO-VG-320 Grade	
	Part Number
Quart	813-106-004
Gallon	813-106-005
Case (12 qts)	813-106-007

700 Series DVJ Parts

Item Number	Part Name	Quantity
01	Headplate	2
3	Gearbox	1
4	Gear, Assembly	1
5	Drive End Cover	1
7	Gasket	2
9	Lubrication Label	2
10	Shim Set	1
11	Cylinder	1
12	Impeller & Shaft - Drive	1
13	Impeller & Shaft - Driven	1
14	Bearing Roller	4
16	Dowel Pin	4
17	Drive-Lok Pin	2
19	Key	1
20	Drive Screw	3
21	Plug - Vent	2
22	Drain - filler Plug	8
23	Cap Screw	36 (700)
27	Seal-Lip, Headplate	4
28	Seal-Ring	4
29	Washer, Wavy Spring	2
31	Locknuts	2
32	Capscrew	16
33	Seal, Lip	1
34	Clamp Plate - Drive End	2
35	Lock Washer	16
37	Oil Level Gauge	2
38	Sleeve - Piston Ring	4
40	Slinger - D.E (Top Drive)	1
40	Slinger - D.E. (Bottom Drive)	2
45	Pipe Plug	2
46	Slinger - G.E.	1
54	Clamp Plate - Gear End	2
55	Capscrew-butt. Hd	2
56	Washer	2
58	Plt Dvr 12" Flg	1
59	Scr, Cap Hex H	12
60	Capscrew	1
63	Lifting Lug	2
64	Pin, Spr (Top Drive)	1
65	Coupling	2
66	Nipple-pipe (700)	2
71	Scr, Set Soch CP (Bottom Drive)	1
73	Foot - R.H.	2
74	Foot - L.H.	2
78	Capscrew - Hex Hd.	2

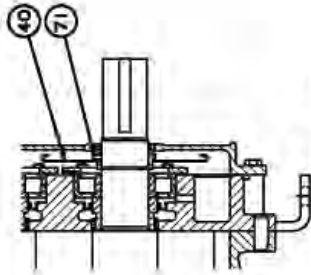
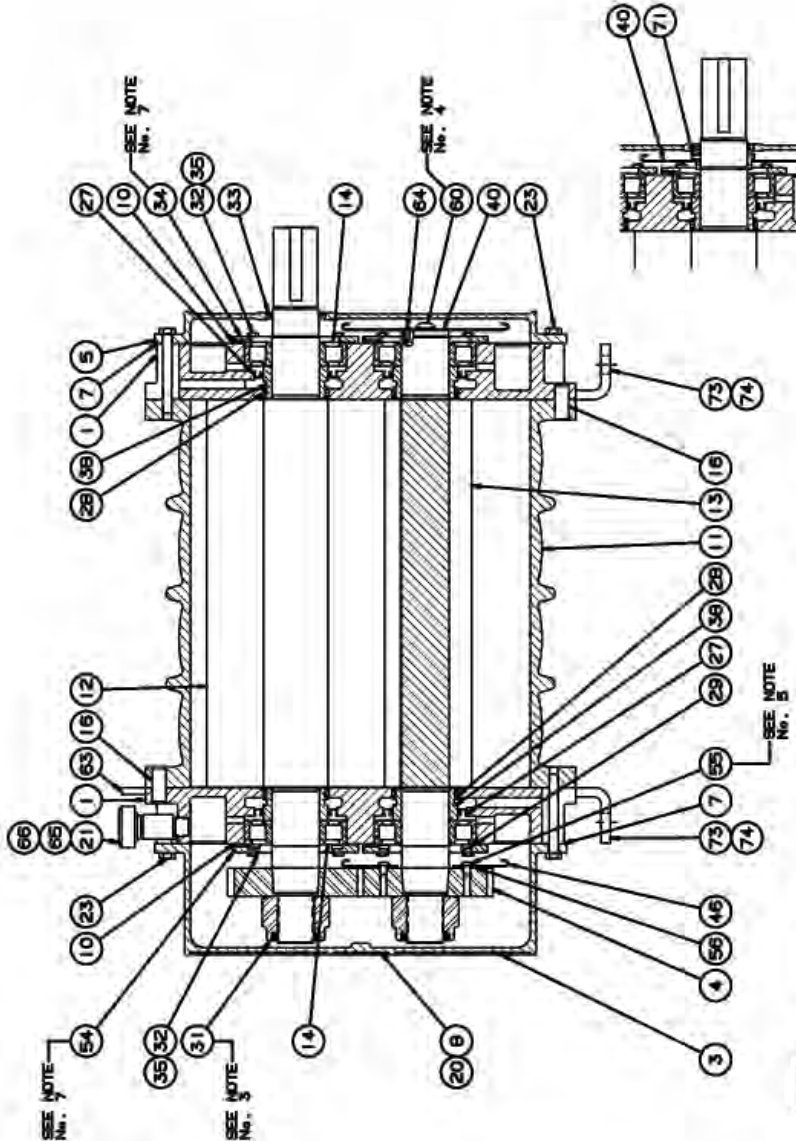
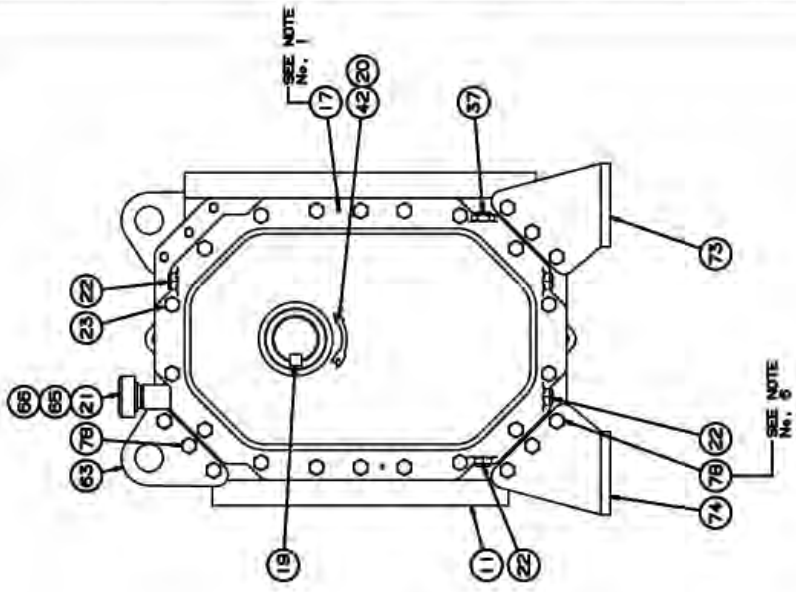

OPTIONAL BOTTOM DRIVE

NOTES:

1. DRIVE END COVER TO BE PINNED TO HEADPLATE AFTER ALIGNING SEAL BORE TO SHAFT WITHIN .001".
2. USE JOHN CRANE PLASTIC LEAD No. 2 ON ALL PIPE THREADS
3. APPLY OIL TO NUT THREADS & NUT FACE AND TORQUE TO 1250 FT.-LBS. (IF MOLYKOTE GN PASTE IS USED TORQUE TO 1000 FT.-LBS.)
4. APPLY LOCKTITE TO SCREW THREADS & TORQUE TO 140 FT.-LBS.
5. APPLY LOCKTITE TO SCREW THREADS & TORQUE TO 25 FT.-LBS.
6. APPLY OIL TO SCREW THREADS & TORQUE TO 85 FT.-LBS.
7. ITEMS 34 & 54 MUST BE INSTALLED WITH OIL GROOVE AT TOP.

FOR PARTS INFORMATION, CONTACT THE MANUFACTURER OF THIS PRODUCT OR THE MANUFACTURER OF THE ORIGINAL EQUIPMENT. THE MANUFACTURER OF THE ORIGINAL EQUIPMENT SHALL BE RESPONSIBLE FOR ANY OVERHAULS.

1. JOHN CRANE
2. MOLYKOTE
3. JOHN CRANE
4. JOHN CRANE
5. JOHN CRANE
6. JOHN CRANE
7. JOHN CRANE

REV.	DATE	DESCRIPTION	BY	CHKD.
1	10/10	SECTIONAL ASSEMBLY		
Roots 72015023				

Sectional Assembly 700 DVJ

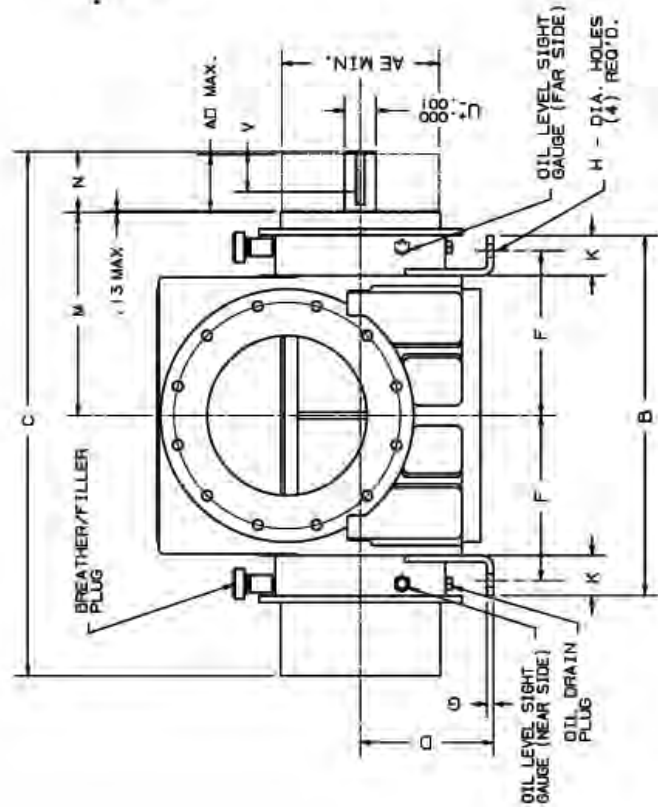

* TO FACE OF JET INLET FLANGE
JET INLET OPENING LOCATED ON
BOTH SIDES OF BLOWER, ONLY
ONE SIDE TO BE USED, AS JET
INLET. OTHER OPENING TO BE
CLOSED WITH STEEL COVER PLATE,
SUPPLIED BY ROOTS.

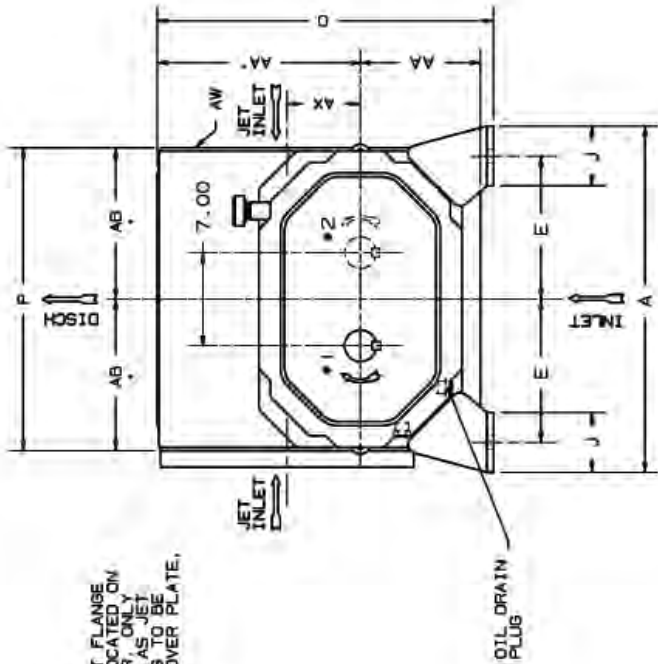

POSITION #1 FURNISHED
UNLESS SPECIFIED OTHERWISE
ALTERNATE POSITION #2
ALSO AVAILABLE

W - INLET & DISCHARGE
AD - SHEAVE WIDTH
AE - SHEAVE DIAMETER
AW - JET INLET

ALL DIMENSIONS IN INCHES

OPENING	12" FLG
BOLT CIRCLE	12.00
FLANGE O.D.	17.00
NO TAPPED HOLES	12
SIZE HOLES	7/8-9
TAP DEPTH	1.31

700 DVJ-H DRY VACUUM WHISP AIR BLOWER

FRAME SIZE	A	B	C	D	E	F	G	H	J	K	M	N	O	P	U	V	KEYWAY	W	AA	AA*	AB	AD	AE	AW	AX	APPROX. WEIGHT
721	26.00	27.00	39.38	10.00	10.75	12.38	1.50	1.00	4.50	3.00	15.25	4.56	25.25	22.75	2.375	3.00	.625 x .313	12" FLG	9.00	15.25	11.38	4.43	11.80	12" FLG	5.50	1.750

INLET AND DISCHARGE FLANGES TO MATE
FLUSH AND SQUARE WITH FLAT FACE
FLANGES ONLY. USE FULL FACE GASKETS
FOR V-BELT DRIVEN UNITS
MOTOR TO BE LOCATED ON
DRIVE SHAFT SIDE OF BLOWER

A-REVISED APPROX. WEIGHT JHB 11-9-93

RE 2/10/93

RDA

DB

73983021

73983421

/PARTS/XXAO

700 DVJ-H Blower

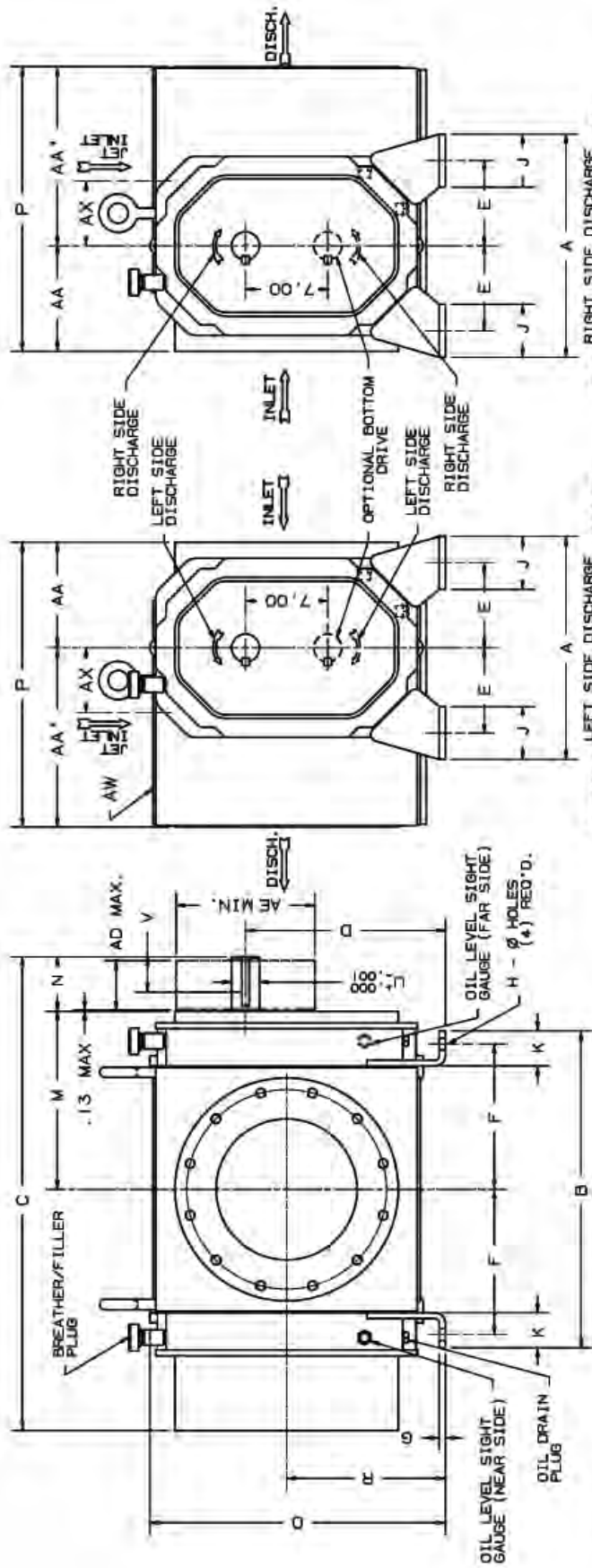

INLET AND DISCHARGE FLANGES TO MATE FLUSH AND SQUARE WITH FLAT FACE FLANGES ONLY. USE FULL FACE GASKETS FOR V-BELT DRIVEN UNITS MOTOR TO BE LOCATED ON INLET SIDE OF BLOWER

LEFT SIDE DISCHARGE FURNISHED UNLESS OTHERWISE SPECIFIED

RIGHT SIDE DISCHARGE FURNISHED ONLY WHEN SPECIFIED

OPENING	12" FLG
BOLT CIRCLE	12.00
FLANGE O.D.	17.00
No. TAPPED HOLES	12
SIZE HOLES	7/8-9
TAP DEPTH	1.31

W - INLET & DISCHARGE AD - SHEAVE WIDTH AE - SHEAVE DIAMETER AW - JET INLET

700 DVJ DRY VACUUM WHISKAIR BLOWER

FRAME SIZE	A	B	C	D	E	F	G	H	J	K	M	N	O	P	R	U	V	KEYWAY	W	AA	AA'	AD	AE	AW	AX	APPROX. WEIGHT	
72	19.00	27.00	39.38	17.00	7.25	12.38	.50	1.00	4.50	3.00	15.25	4.56	24.88	24.25	13.50	2.375	3.00	825	x .313	12" FLG	9.00	15.25	4.43	11.80	2" FLG	5.50	1750

ALL DIMENSIONS IN INCHES

C-C-80 LIFTING LUGS NIP 10/19/95 4369V
 B-REVISED APPROX. WEIGHT JHB 10-21-93
 A-CORRECTED GREATHER RVE 2/24/93

*PARTS/00AD

JHB 10-21-93 DB DLB 1/8/93 873-962-021 XXAD 73962A21

700 DVJ Blower

About Dresser Roots®

Dresser Roots, a major product brand of Dresser, Inc., is the manufacturer of the original ROOTS blower™, centrifugal compressors and control systems. ROOTS® air and gas moving equipment is used in a wide variety of applications, including Mechanical Vapor Recompression, water and wastewater treatment, flue gas desulphurization, petrochemical and chemical processes, conveying, and other industrial applications.

About Dresser, Inc.

Dresser, Inc. is a leader in providing highly engineered infrastructure products for the global energy industry. The company has leading positions in a broad portfolio of products, including valves, actuators, meters, switches, regulators, piping products, natural gas-fueled engines, retail fuel dispensers and associated retail point-of-sale systems, and air and gas handling equipment. Leading brand names within the Dresser portfolio include Dresser Wayne® retail fueling systems, Waukesha® natural gas-fired engines, Masonellan® control valves, Consolidated® pressure relief valves, and Roots® blowers. It has manufacturing and customer service facilities located strategically worldwide and a sales presence in more than 100 countries.

Dresser Roots

Houston, Texas Headquarters • U.S. Toll Free Phone: 1 877-363-ROOT(S) (7668) • Direct Phone: +1 832-590-2600
Connersville, Indiana Operations • U.S. Toll Free Phone: 1 877-442-7910 • Direct Phone: +1 765-827-9285
United Kingdom Operations • Phone: +44 (0) 1695 52600
USA/Canada Sales • Phone: +1 773-444-3360
Houston, Texas Factory Service • Phone: +1 713-896-4810
Mexico City Sales and Factory Service • Phone: +52 55 5889 5811
Dubai Sales and Factory Service • Phone: +971 4-8855481
Malaysia Sales • Phone: +60 3 2163 0480
China Sales • Phone: +86 10 8486 2440
Shanghai Factory Service • Phone: +86 21 5858 7638



©2010 Dresser, Inc. All rights reserved. • Printed in the U.S.A. • All information subject to change without notice. • Roots, Wayne, Waukesha, Masonellan and Consolidated are registered trademarks of Dresser, Inc. • ROOTS and WHISPAIR, are trademarks of Dresser, Inc.