

# F65

# INLINE AIR FILTERS

## INLINE AIR FILTERS - PRESSURE SERVICE

The Series F65 Inline Air Filter is designed to mount directly in the air piping system for engines, blowers or compressors. The filter element, which is fabricated from pleated paper media, has an efficiency of 99% on 1 micron particles and larger. The housing is designed to withstand an internal pressure of 15 psig. Pressure taps are provided on the intake and discharge nozzles for installation of a pressure drop indicator or switch by the customer. The F65 Inline Air Filter surfaces are prime coated with a red oxide primer.

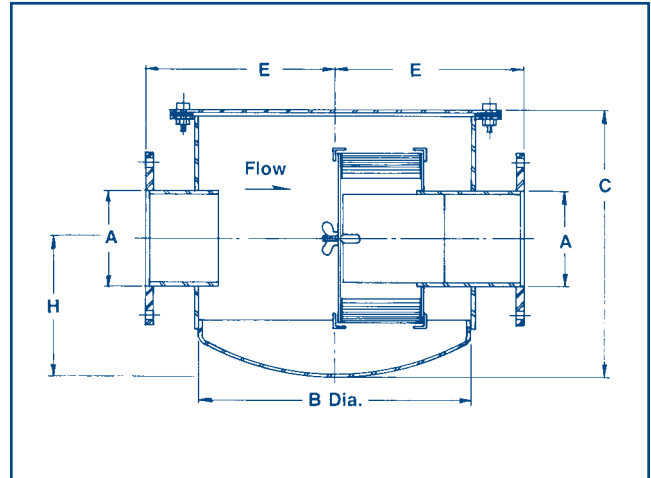

### ALTERNATE FILTRATION MEDIA AVAILABLE FOR F65

- Cleanable Polyurethane Foam - 98% on 10 micron particles
- Cleanable Polyester Felt - 98% on 3 micron particles
- Epoxy Coated Wire Mesh - 90% on 10 micron particles  
(When Oil Wetted)

FOR VACUUM SERVICE USE F65V (See Page 3)

## F65 SERIES

MODEL	A	B	C	E	H	RATED CFM <sup>(1)</sup>	WEIGHT	REPLACEMENT ELEMENT NUMBER
F65-2	2 NPT	12	10 <sup>3</sup> / <sub>4</sub>	9	5	135	38	F8-108
F65-2 <sup>1</sup> / <sub>2</sub>	2 <sup>1</sup> / <sub>2</sub> NPT	12	10 <sup>3</sup> / <sub>4</sub>	9	5	180	40	F8-108
F65-3	3 NPT	16	15 <sup>1</sup> / <sub>4</sub>	11	7	285	70	F8-109
F65-4	*4 FLG	16	15 <sup>1</sup> / <sub>4</sub>	11	7	520	77	F8-109
F65-5	*5 FLG	16	15 <sup>1</sup> / <sub>4</sub>	11	7	750	80	F8-109
F65-6	*6 FLG	18	18 <sup>5</sup> / <sub>8</sub>	12	10	1075	100	F8-110
F65-8	*8 FLG	24	19 <sup>1</sup> / <sub>2</sub>	15	10	1800	180	F8-111
F65-10	*10 FLG	36	37	22	17	3335	390	F8-137
F65-12	*12 FLG	36	37	22	17	4675	415	F8-137
F65-14	*14 FLG	36	37	22	17	5655	435	F8-137

\*Flanges match 125# ASA. Diameter and Drilling.

(1) Rated capacity is based upon a maximum exit velocity of 5500 fpm.